

Energy Division

HVIA STRIPPER

Stripping tool for cable screens and primary insulation for cable diameters from 35 to 150 mm

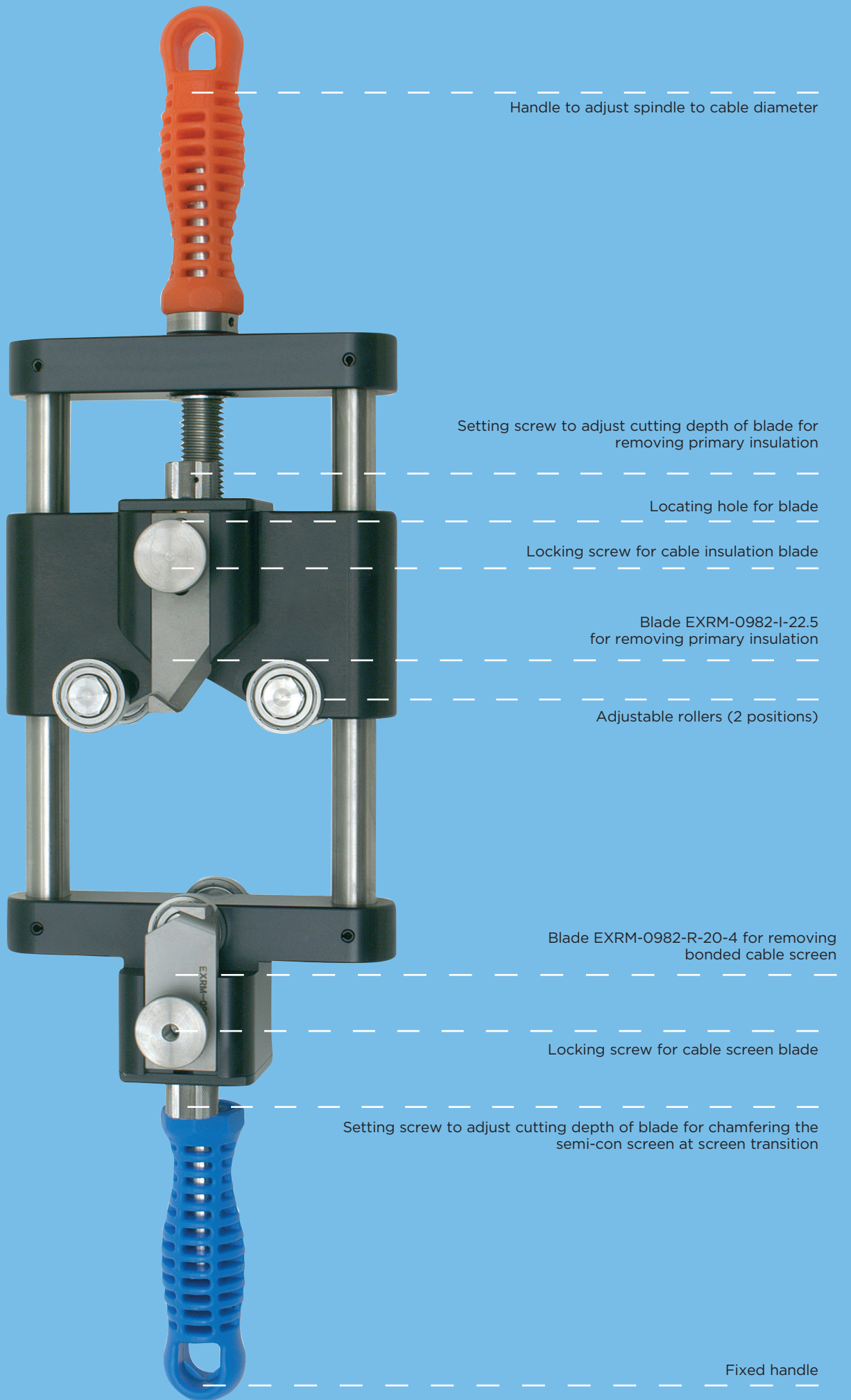

Handle to adjust spindle to cable diameter

Setting screw to adjust cutting depth of blade for removing primary insulation

Locating hole for blade

Locking screw for cable insulation blade

Blade EXRM-0982-I-22.5 for removing primary insulation

Adjustable rollers (2 positions)

Blade EXRM-0982-R-20-4 for removing bonded cable screen

Locking screw for cable screen blade

Setting screw to adjust cutting depth of blade for chamfering the semi-con screen at screen transition

Fixed handle



The stripping blade is adjustable.

Coarse adjustment: Remove locking screw and reposition blade.

Fine adjustment: Loosen locking screw to adjust blade to desired cutting depth via the setting screw.



Adjust rollers to cable diameter until they are in contact with the bonded screen.

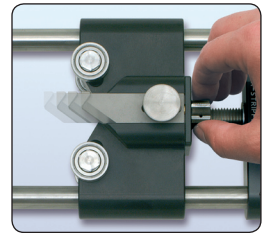
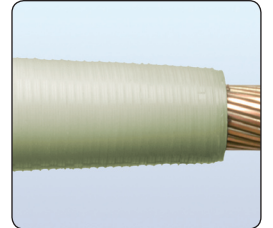
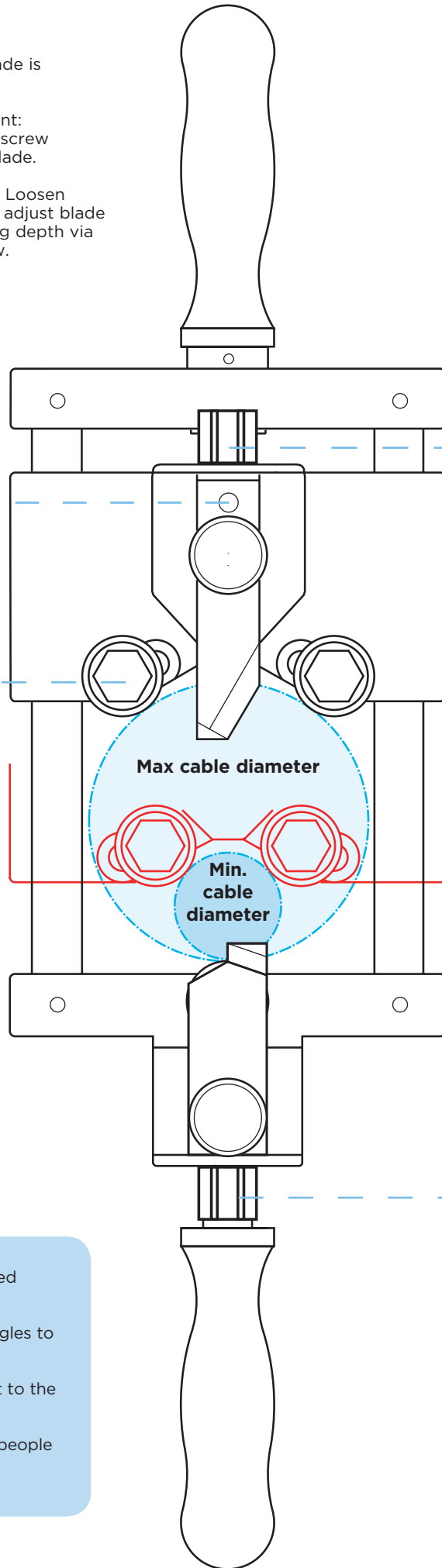

Loosen locking screw to adjust blade to desired cutting depth.

Loosen locking screw to adjust blade to desired cutting depth.

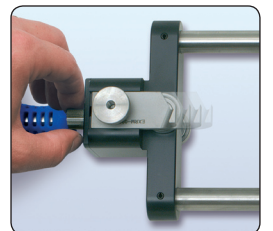

Notes:

The tool is supplied with blades packed separately in the case.

The cable must be aligned at right angles to the stripper tool.

Apply a thin layer of silicone lubricant to the bonded screen for easy movement.

The tool should be operated only by people trained in handling this type of tool.

Ordering Information

Part Number	Cable Diameters
HVIA-Stripper 35/90-US	35mm - 90mm
VVIA-Stripper 75/150-US	75mm - 150mm

All of the above information, including drawings, illustrations and graphic designs, reflects our present understanding and is to the best of our knowledge and belief correct and reliable. Users, however, should independently evaluate the suitability of each product for the desired application. Under no circumstances does this constitute an assurance of any particular quality or performance. Such an assurance is only provided in the context of our product specifications or explicit contractual arrangements. Our liability for these products is set forth in our standard terms and conditions of sale. ShrinkMark, Insta-Mark, Raychem, TE logo and Tyco Electronics are trademarks.

Energy Division - a pioneer in the development of economical solutions for the electrical power industry. Our product range includes: Cable accessories, connectors & fittings, electrical equipment, instruments, lighting controls, insulators & insulation enhancement and surge arresters.

Tyco Electronics Corporation
8000 Purfoy Road
Fuquay Varina, NC 27526-9349
Tel: 800.327.6996
Fax: 800.527.8350
E-mail: naenergy@tycoelectronics.com
<http://energy.tycoelectronics.com/>
www.tycoelectronics.com

© 2007 Tyco Electronics Corporation. All rights reserved.
7-1773447-4 E270 8/07



Our commitment. Your advantage.