

RAYCHEM HIGH VOLTAGE CABLE ACCESSORIES

UP TO 245 KV

Content

TE Connectivity.....	4
High Voltage Cable Accessories.....	5
Our core Competencies.....	6
Services.....	7

I. High Voltage Cable Terminations



Heat-Shrinkable Terminations IHVT-H/ OHVT-H/ LHVT-H	10
Heat-Shrinkable Terminations for DC Filter Cables FCEV.....	14
Outdoor Terminations Composite OHVT-C.....	17
Outdoor Terminations Porcelain OHVT-P.....	22
Outdoor Terminations Dry-type OHVT-D	27
Add-On Kits for Outdoor Terminations	28

II. High Voltage Dry Plug-In Terminations



Dry Plug-In Switchgear and Transformer Terminations.....	32
Add-On Kits for Dry Plug-In Switchgear and Transformer Terminations PHVS & PHVT.....	41
and Transformer Terminations PHVS & PHVT.....	41

III. High Voltage Cable joints



Heat-Shrinkable Joint EHVS-H.....	46
One Piece Joint EHVS-S	48
Three Piece Joint EHVS-T.....	51
Fibre-Optic Add-On Kit for HV Cable Joints	54

IV. High Voltage Connectors



High Voltage Connector for Outdoor Terminations.....	58
--	----

V. Link Boxes

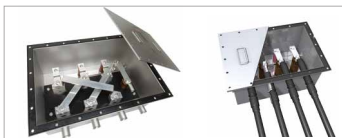

Link Boxes.....	64
Link Boxes Selection Tables.....	66

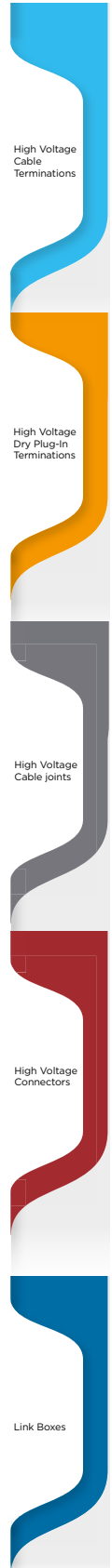

TE Connectivity

TE Connectivity (TE) unites world-leading high voltage component brands under a single company. Individually, each has forged a reputation for innovation, reliable performance and ease of installation. Collectively, they assure you that TE delivers uncompromising performance for components throughout your substation project.

- Bowthorpe EMP – Surge Arresters and Surge Counters
- Raychem – MV and HV Cable Accessories, Insulators, Wildlife and Asset Protection
- AXICOM – MV and HV Insulators and Bushings
- SIMEL – Substation Connectors, Grounding Connectors and Earthing Material



Bowthorpe EMP surge protection

Choose from a family of surge arrester products from 3 kV – 800 kV, IEEE or IEC qualified, in porcelain or polymeric housings.

- Intermediate class arresters
- Station class arresters
- Transmission line arresters
- Surge counters
- Cable sheath surge arresters - CSPA range

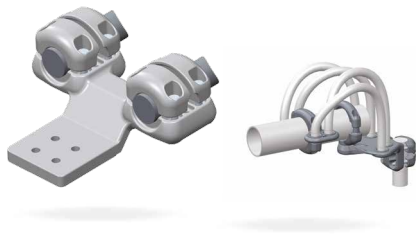

SIMEL substation connectors

Draw upon our years of field experience in HV substations worldwide. Our engineers are here to help you specify the ideal product package.

- Clamps, connectors and insulators strings for HVAC and HVDC applications up to 1200 kV
- Earthing and grounding connections
- Bare Conductors



AXICOM insulators

Turn to us to help you define needs and specify products to meet your application requirements, or to design highly customized solutions to meet specific mechanical requirements or environmental demands.

- Hollow-core composite insulators
- Suspension-tension insulators
- Disc insulators: glass and porcelain
- Station-post composite insulator



Raychem cable accessories

Well known as a worldwide leader in heatshrink polymer based materials, TE is also a center of excellence for cold-applied and resin technologies. Network owners know they are getting products with proven electrical and mechanical performance, while installers benefit from faster, safer and more cost-effective installation.

- Terminations and joints
- Link boxes
- Elbows
- Earthing and grounding systems
- Casting and potting resins
- And much more



High Voltage Cable Accessories



Energy business unit headquarter situated in Ottobrunn (close to Munich), Germany

The brands that make up TE's portfolio of high voltage components represent more than 5 decades product line experience in power transmission business. This long-term track record, with projects all over the world, is united under a single company to provide you with a single source of supply. Our global network of technical and sales representatives provides expert application and engineering assistance, hands-on field training and continuous after-sales support to help our customers successfully master the challenges of today's businesses.

Expertise in materials science, product design and process engineering go into the invention, development, manufacture and marketing of our high-performance products. Our competitive advantages are well recognized in the market:

- Customer focused organization
- Innovation and technology driven
- Extensive product offering
- Multiple market segments presence
- Industry leadership and expertise
- Structural and financial strength

Our wide range of reliable and cost-effective solutions is continuously expanded through research-driven product development.

The most innovative utilities and industries around the world use our high voltage cable accessories. Designed to withstand environmental extremes and high pollution levels over long operating lifetimes, they help maintain service reliability in both overhead and underground installations.

All Raychem high voltage cable accessories products are subjected to extensive testing from the time they enter our plants as raw material until they leave as finished products. Requalification testing is carried out on a regular basis with installed components. Customers can thus have full confidence in the products, services and data supplied. In many cases, this saves the cost and inconvenience of any further downstream verification. All our electrical power products meet international specifications, such as IEC, CENELEC, IEEE, ANSI, and virtually all national standards.

With manufacturing facilities across five continents, we can react promptly to customer requirements and keep lead times and shipping distances to a minimum. An effective product supply chain ensures products move from origin to installation without lag time. Local customer service centers offer a single point of contact with staff that can provide country-specific support based on the needs of each region. By combining local knowledge with world-class research, product development and manufacturing capabilities, we set high standards of performance and user convenience. ISO 9000 series and ISO 14001 certifications for almost all locations underline our continuing commitment to quality and the environment.

Our core competencies



Understanding the value of high voltage cable accessories as essential elements in a cable system

Since the foundation of Raychem in 1957 we are specialized in the development, design, manufacturing and installation of cable accessories so that we are experts for this kind of product within electrical power engineering. Consequently our expertise in this field for these components will offer you reliable and safe components in your complete cable system.

Manufacturing and quality assurance of high voltage insulation systems

With latest manufacturing technology and quality management processes we keep up the efficiency and thereby offer competitive high voltage cable accessories. We have material expertise as well as test facilities for all related fluid, gaseous and solid insulation material developments, which will be used in our complete range of high voltage cable accessories resulting in maximum product lifetime for our customers. In addition we are producing and using our own raw material which will allow us to optimize the material properties perfectly on our customer needs.



Electrical, mechanical and thermal design of high voltage cable accessories and respective connectors

The design of our high voltage accessories are based on knowledge within electrical, mechanical and thermal performance. It is essential to understand the interaction between these physical parameters since all of them have major impact on the reliability of high voltage cable accessories. We have long extensive experience and use modern software that allows us to simulate the physical environments which our accessories are going to face. Further on we are the only cable accessories manufacturer worldwide which have all existing stress control systems (geometrical, resistive, refractive and non-linear) in either heat shrink or cold applied technology in our portfolio.

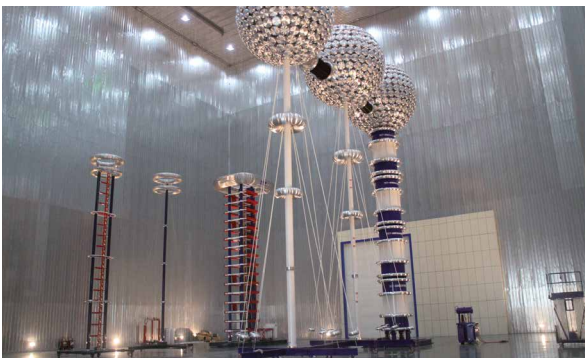

Realize the importance of all other components being used in high voltage cable accessories on the performance

For the successful operation of high voltage cable accessories it is essential to understand the influence of other related components which are used in high voltage cable accessories such as hollow core insulators, mechanical connectors. Based on this fact we design, produce and test all these components in-house and minimize negative influence on the performance of the final product. With this strategy we can ensure that the product will deliver what we promise.

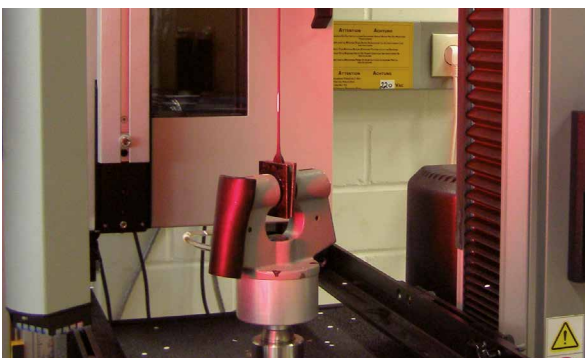

Services

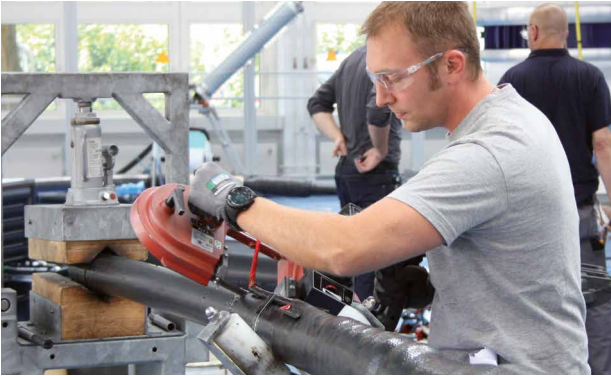

Training

As a supplier of high voltage accessories TE also offers training services. In our training centers around the world we conduct customized training courses in small training groups. Experienced supervisors show the general assembly of high voltage accessories as well as the detailed installation of TE high voltage products. Depending on the experience of the trainees the training can be organized individually. Every training course includes:

- Theoretical product training
- Individual HV cable preparation session
- Complete installation of TE HV cable accessories

A certificate is issued to each trainee after a successful completion of the training course.



Supervision

Additionally to our training courses in our labs we offer also supervision for installations on-site. This is for jointers who have been trained by TE supervisors prior to an installation but haven't yet had sufficient on-site experience in installing TE accessories and may need the help of a supervisor. We recommend this service for jointers who install TE accessories on site the first time. This service ensures the accessories are installed according to the installation instruction.



Installation

TE has well-trained and experienced jointers who are able to carry out installation at construction sites. Usually they are supported by local assistance provided by the contractor or the local utility. If there are no trained jointers available locally, ordering installation services from us is the first choice.



Tools

We provide the full range of tools which are necessary to install high voltage cable accessories. Our fully equipped tool box contains not only the tools for preparation of the cable but also components required for a safe and efficient installation on-site.

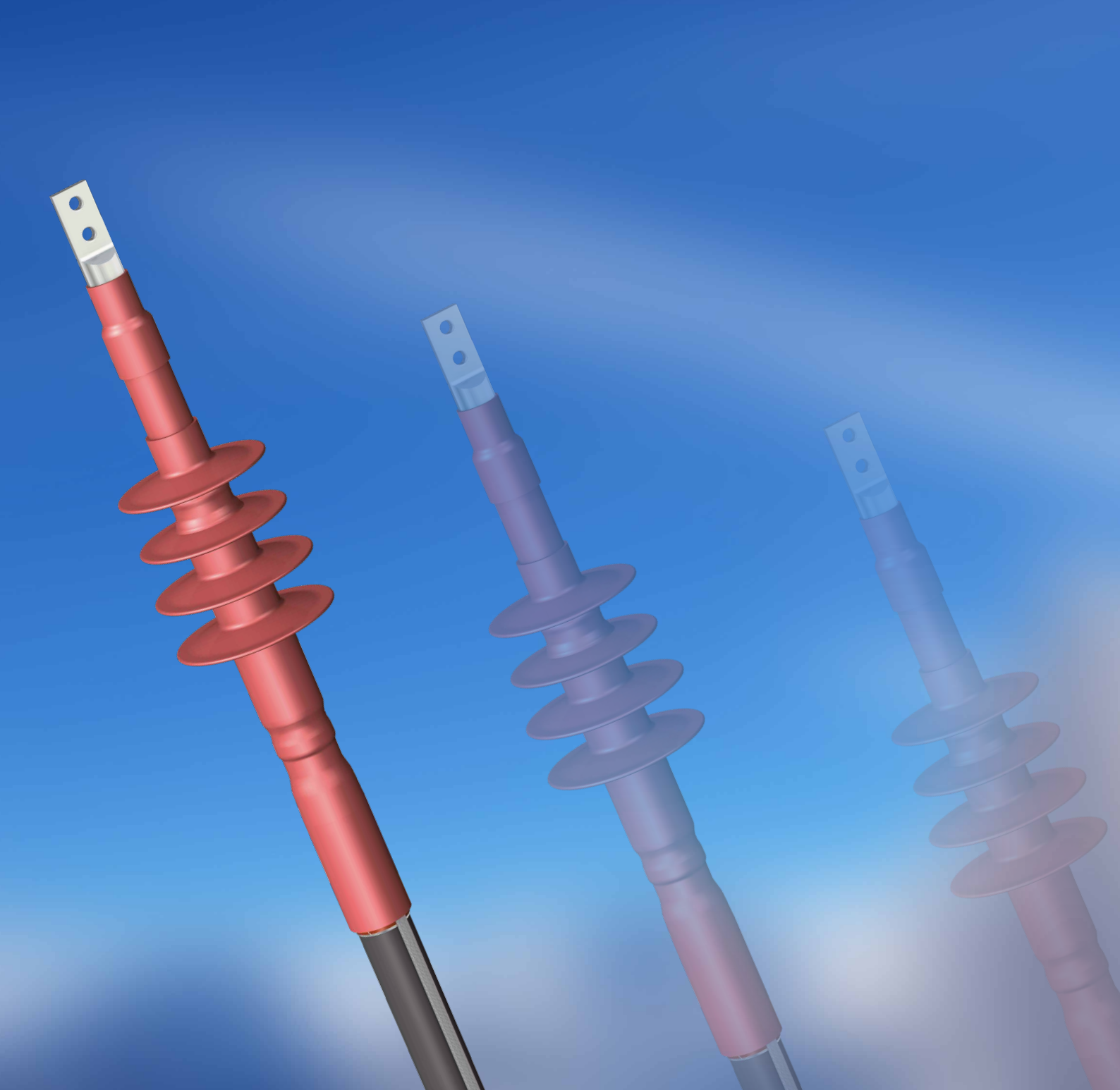



Chapter I

High voltage terminations

- Heat-Shrinkable Terminations IHVT-H/ OHVT-H/ LHVT-H 10
- Heat-Shrinkable Terminations for DC Filter Cables FCEV14
- Outdoor Terminations Composite OHVT-C18
- Outdoor Terminations Porcelain OHVT-P21
- Outdoor Terminations Dry-type OHVT-D26
- Add-On Kits for Outdoor Terminations28



Raychem Heat-Shrinkable Terminations IHVT-H/OHVT-H

APPLICATION

- The TE Connectivity Raychem heat-shrinkable terminations are suitable for all climates, areas, and environments, even severely polluted areas, as well as for all installation conditions, including top feed installation
- Our heat shrink accessories have been used by utilities and industrial companies around the world for more than 50 years

FEATURES

- Compact and modular design
- Heat-shrinkable stress control sleeves
- Non-tracking, heat-shrinkable outer insulation
- Water- and corrosion-resistant
- Different creepage distances available
- Easy to install
- Suitable for compression and mechanical lugs
- No special or expensive tools
- Lightweight components
- Unlimited shelf life under normal storage conditions
- No oil or compound filling
- Reduced waste for disposal

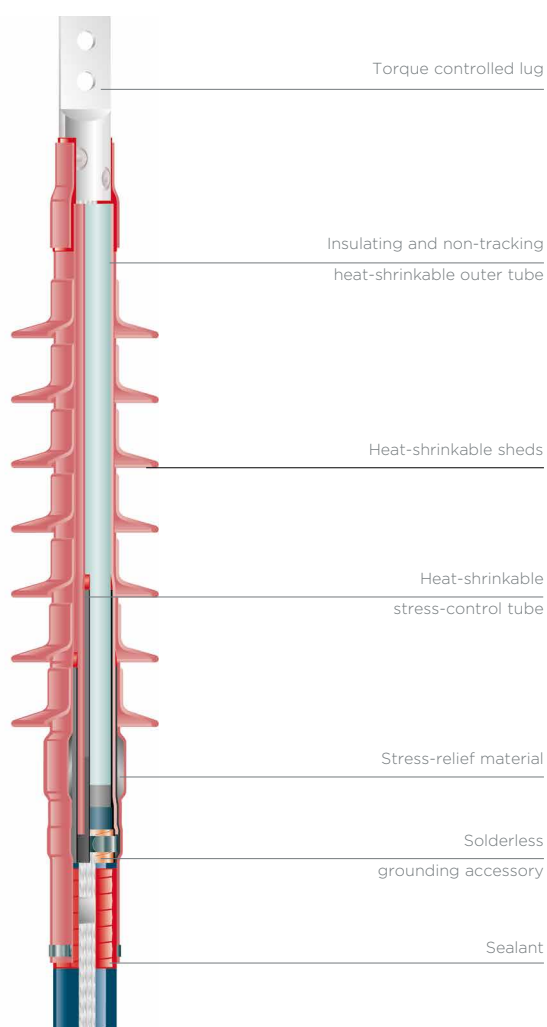

Max. operating voltage U_m (kV)	52	72.5	123
Standards	IEC 60840 IEC 60815	IEC 60840 IEC 60815	IEC 60840 IEC 60815
Rated voltage U (kV)	45 - 47	60 - 69	110 - 115
Rated lightning impulse withstand voltage (BIL) (kV)	250	325	325*

* Reduced level compared to IEC 60840

Raychem Heat-Shrinkable Terminations IHVT-52H/OHVT-52H

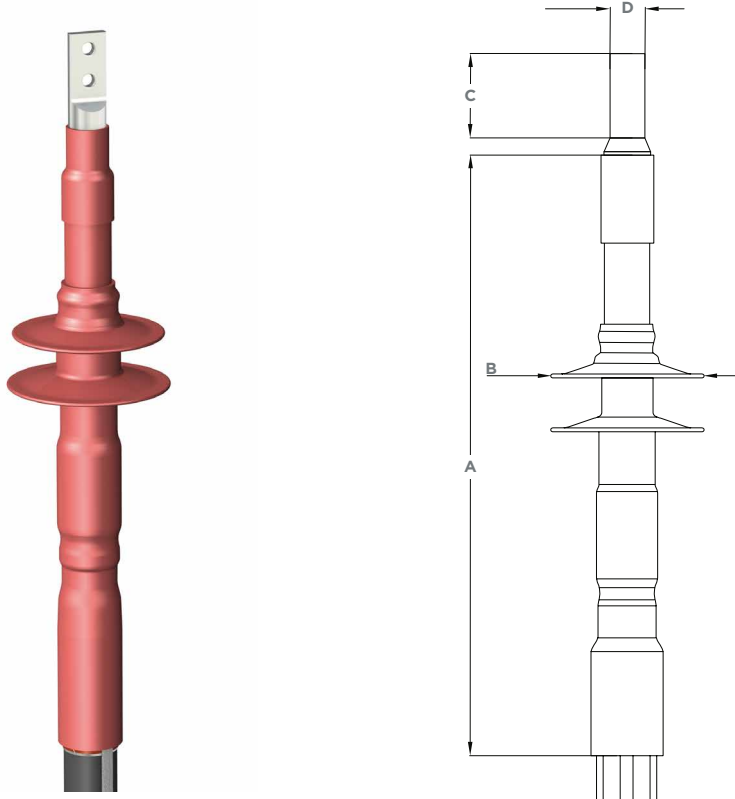

High Voltage Terminations

Technical data

Product description	Conductor cross section (mm ²)	Diameter over cable insulation (prepared) (mm)	Diameter over outer cable sheath (mm)	Creepage distance approx. (mm)
INVT-52H	95 - 2500	30 - 77	60 - 100	1100
OHVT-52H	95 - 2500	30 - 77	60 - 100	1540

Dimensions

Product description	A (mm)	B (mm)	C (mm)	D* (mm)
INVT-52H	800	220	125	30/40/50
OHVT-52H	920	220	125	30/40/50

* Different studs and pads are available on request

Raychem Heat-Shrinkable Terminations IHVT-72H/OHVT-72H/LHVT-72H

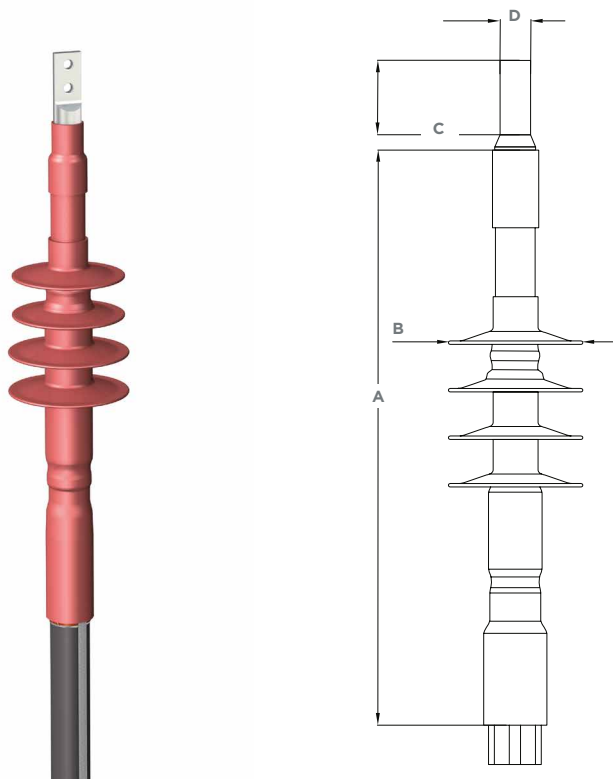

Technical data

Product description	Conductor cross section (mm ²)	Diameter over cable insulation (prepared) (mm)	Diameter over outer cable sheath (mm)	Creepage distance approx. (mm)
INVT-72H	95 - 2500	30 - 86	60 - 110	1600
OHVT-72H	95 - 2500	30 - 86	60 - 110	2300
LHVT-72H	300 - 2500	38 - 86	70 - 110	3100

Dimensions

Product description	A (mm)	B (mm)	C (mm)	D* (mm)
INVT-72H	960	220	120	30/40/50
OHVT-72H	1200	220	125	30/40/50
LHVT-72H	1560	220	125	30/40/50

* Different studs and pads are available on request

Raychem Heat-Shrinkable Terminations OHVT-123H

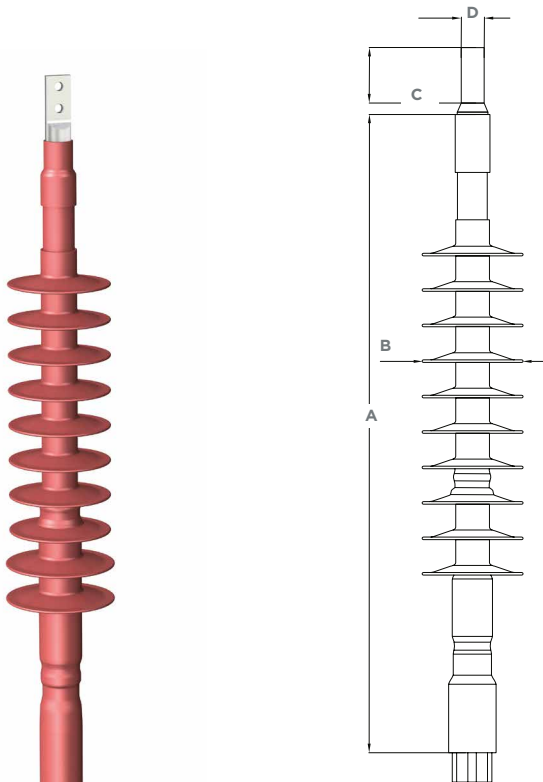

High Voltage Terminations

Technical data

Product description	Conductor cross section (mm ²)	Diameter over cable insulation (prepared) (mm)	Diameter over outer cable sheath (mm)	Creepage distance approx. (mm)
OHVT-123H	95 - 1600	30 - 86	60 - 110	3100

Dimensions

Product description	A (mm)	B (mm)	C (mm)	D* (mm)
OHVT-123H	1560	220	125	30/40/50

* Different studs and pads are available on request

NOTE To be used as a temporary solution only

Raychem Heat-Shrinkable Terminations for DC Filter Cables FCEV

APPLICATION

- The cable is prepared in the same simple and easy way as for Raychem medium voltage terminations without sanding or pencilling. Based on the design of Raychem high voltage terminations, the filter cable termination consists of a staggered layer of stress control tubings and patches. A heat-shrinkable non-tracking insulation tubing and shed are shrunk over the stress control system and ensure a reliable seal to the lug and the oversheath. A mechanical lug is supplied with the kit. The mechanical lug has an M10 thread on the top for easy connection to connecting busbars. The termination is supplied as a single phase termination. A solderless earth connection for cables with metal sheath is included in the termination kit

FEATURES

- Compact and modular design
- Heat-shrinkable stress control sleeves
- Non-tracking, heat-shrinkable outer insulation
- Easy to install
- No special or expensive tools
- Lightweight components
- Unlimited shelf life under normal storage conditions
- No oil or compound filling
- Reduced waste for disposal

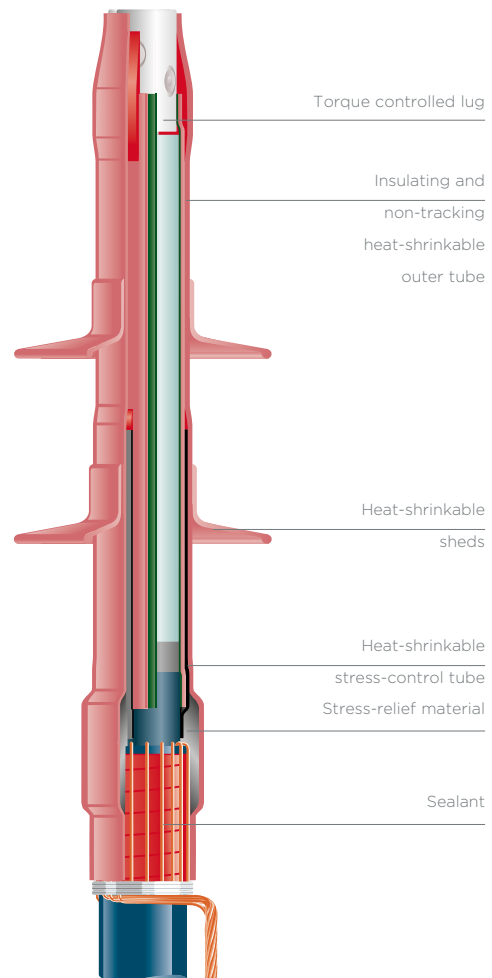

Max. operating voltage U_m (kV)	111	150
DC withstand test (kV)	200	300
Rated lightning impulse withstand voltage (BIL) (kV)	240	325

Raychem Heat-Shrinkable Terminations for DC Filter Cables FCEV

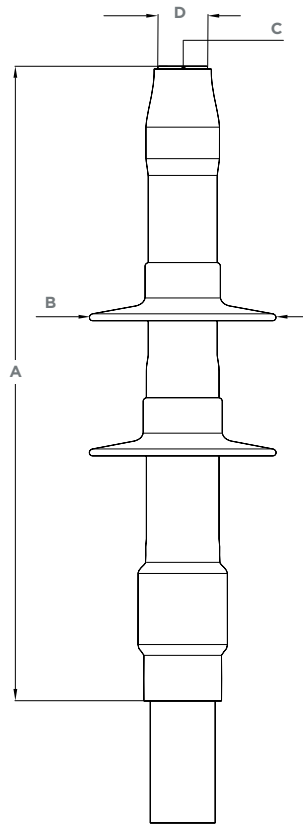

High Voltage Terminations

Technical data

Product description	Load voltage U_L	Diameter over cable insulation (prepared) (mm ²)	Diameter over cable insulation (mm)
FCEV-111	111	35 - 95	26 - 38
FCEV-150	150	35 - 95	26 - 38
FCEV-150-1	150	95 - 240	38 - 52

Dimensions

Product description	A (mm)	B (mm)	C (mm)	D* (mm)
FCEV-111	500	155	M10	32
FCEV-150	700	155	M10	32
FCEV-150-1	700	155	M10	32



Raychem Outdoor Terminations OHVT-C (Composite)

APPLICATION

- The termination is designed for voltage classes up to 245 kV and to operate under severe environmental conditions. Polymeric insulated cables of various designs can be adopted with respect to shielding and metal sheath. Composite housings with different creepage lengths up to 50 mm/kV are available for the most common and also extreme pollution levels according to IEC 60071-1 and IEC 60071-2

FEATURES

- Pressure-tight and light weight composite housing
- Pre-fabricated and factory-tested Silicone-rubber stress cone
- Torque-controlled conductor bolt
- No special tools required to install the termination
- Silicone-oil filling without preheating
- Insulated base plate for sectionalization
- Fittings made of corrosion-resistant alloy
- Type tested according to IEC 60840 and IEC 62067 standards

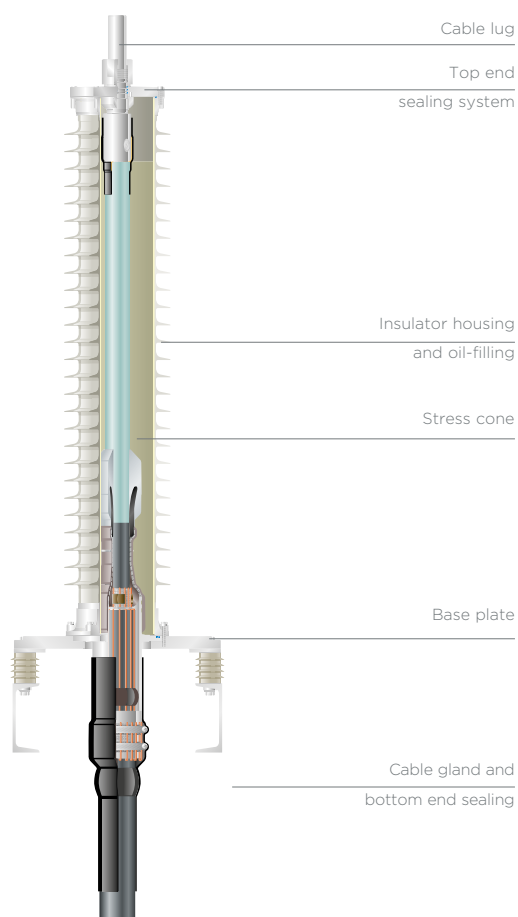

Max. operating voltage U_m (kV)	72.5	123	145	170	245
Standards	IEC 60840 IEC 60815	IEC 60840 IEC 60815	IEC 60840 IEC 60815	IEC 60840 IEC 60815	IEC 62067 IEC 60815
Rated voltage U (kV)	60 - 69	110 - 115	132 - 138	150 - 161	220 - 230
Rated lightning impulse withstand voltage (BIL) (kV)	325	550	650	750	1050

Raychem Outdoor Terminations OHVT-72C

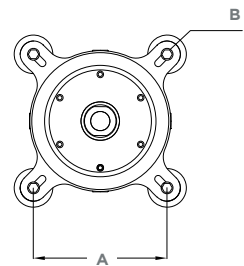
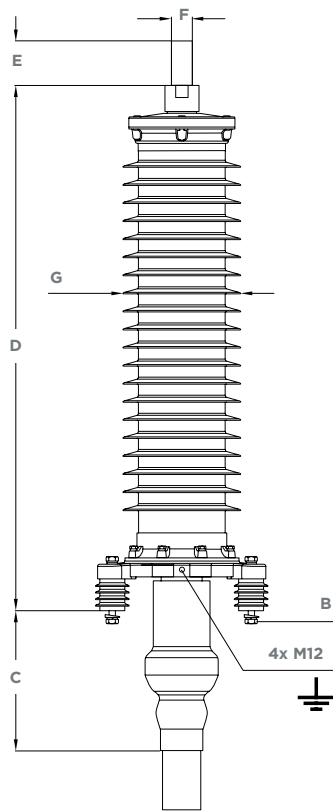

High Voltage Terminations

Technical data

Product description	Conductor cross section (mm ²)	Diameter over cable insulation (prepared) (mm ²)	Max. diameter over outer cable sheath (mm)	Minimal creepage distance (mm)
OHVT-72C (-2A)	95 - 2500	34 - 97	110	2164
OHVT-72C (-2B)	95 - 2500	34 - 97	110	2383
OHVT-72C (-2C)	95 - 2500	34 - 97	110	3089

Dimensions

Product description	A (mm)	B (mm)	C (mm)	D (mm)	E (mm)	F (mm)	G (mm)
OHVT-72C (-2A)	300 - 345	M16	350	1276	100/130	30/40/50	294
OHVT-72C (-2B)	300 - 345	M16	350	1072	100/130	30/40/50	304
OHVT-72C (-2C)	300 - 345	M16	350	1262	100/130	30/40/50	308

Raychem Outdoor Terminations OHVT-145C

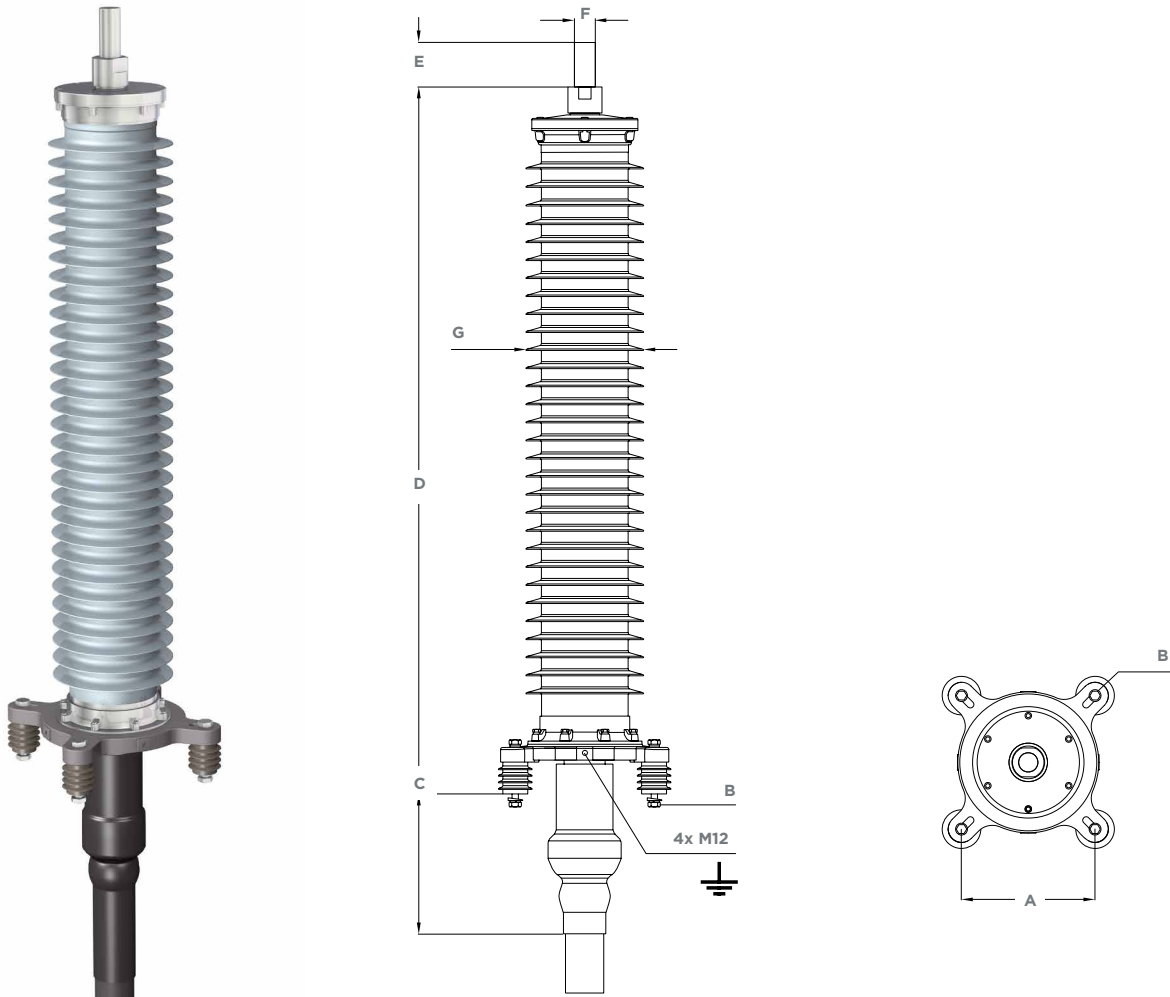

Technical data

Product description	Conductor cross section (mm ²)	Diameter over cable insulation (prepared) (mm)	Max. diameter over outer cable sheath (mm)	Minimal creepage distance (mm)
OHVT-145C (-2A)	95 - 2500	34 - 97	110	3392
OHVT-145C (-3A)	95 - 2500	34 - 97	110	3829
OHVT-145C (-4A)	95 - 2500	34 - 97	110	4684
OHVT-145C (-4B)	95 - 2500	34 - 97	110	6100
OHVT-145C (-4C)	95 - 2500	34 - 97	110	8047

Dimensions

Product description	A (mm)	B (mm)	C (mm)	D (mm)	E (mm)	F (mm)	G (mm)
OHVT-145C (-2A)	300 - 345	M16	350	1771	100/130	30/40/50	294
OHVT-145C (-3A)	300 - 345	M16	350	1951	100/130	30/40/50	294
OHVT-145C (-4A)	300 - 345	M16	350	1696	100/130	30/40/50	304
OHVT-145C (-4B)	300 - 345	M16	350	2080	100/130	30/40/50	304
OHVT-145C (-4C)	300 - 345	M16	350	2608	100/130	30/40/50	304

Raychem Outdoor Terminations OHVT-170C

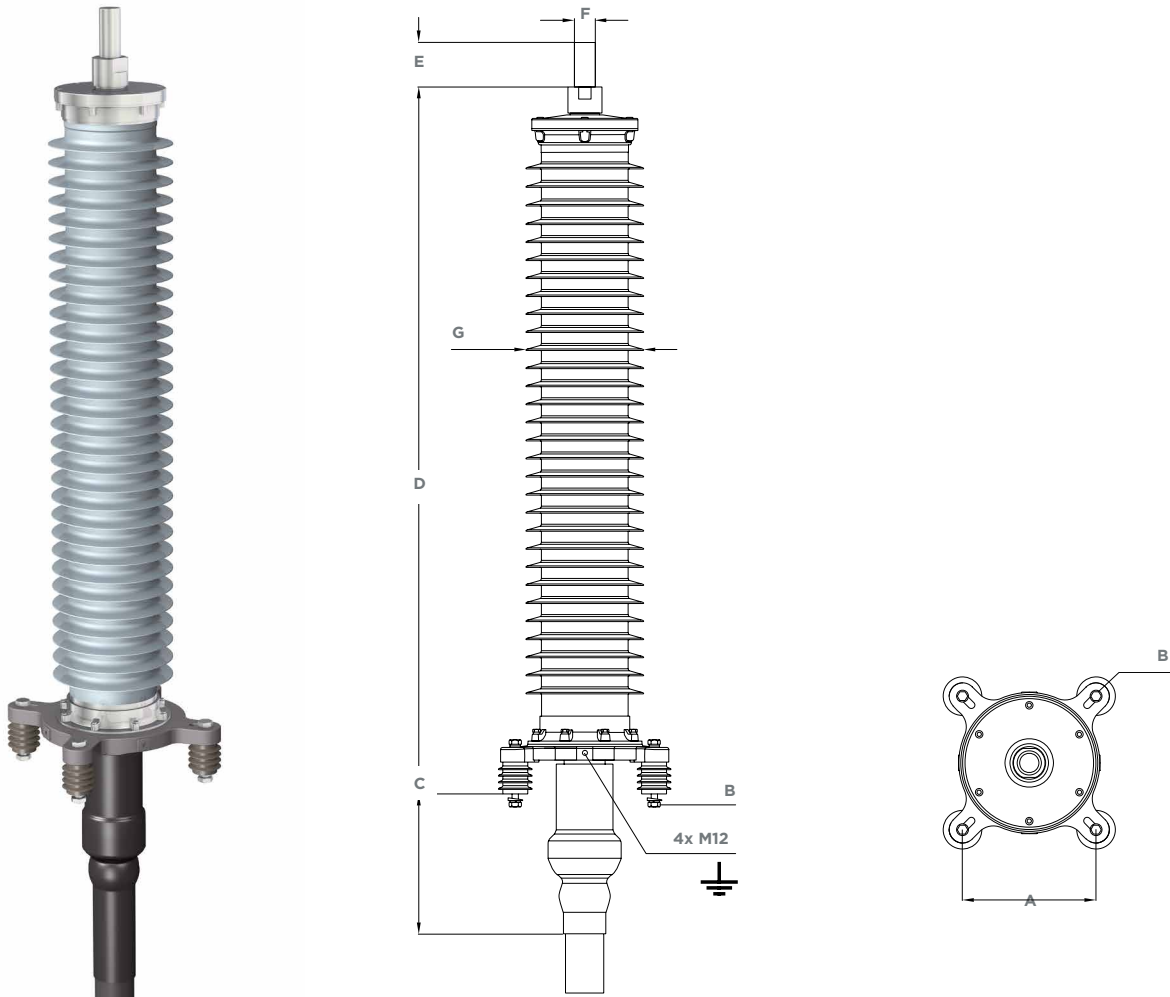

High Voltage Terminations

Technical data

Product description	Conductor cross section (mm ²)	Diameter over cable insulation (prepared) (mm)	Max. diameter over outer cable sheath (mm)	Minimal creepage distance (mm)
OHVT-170C (-1A)	95 - 2500	43 - 108	135	3829
OHVT-170C (-3A)	95 - 2500	43 - 108	135	4273
OHVT-170C (-4A)	95 - 2500	43 - 108	135	5373
OHVT-170C (-4B)	95 - 2500	43 - 108	135	5746
OHVT-170C (-4C)	95 - 2500	43 - 108	135	9436

Dimensions

Product description	A (mm)	B (mm)	C (mm)	D (mm)	E (mm)	F (mm)	G (mm)
OHVT-170C (-1A)	300 - 345	M16	350	2028	100/130	30/40/50	345
OHVT-170C (-3A)	300 - 345	M16	350	2224	100/130	30/40/50	345
OHVT-170C (-4A)	300 - 345	M16	350	2614	100/130	30/40/50	345
OHVT-170C (-4B)	300 - 345	M16	350	2056	100/130	30/40/50	345
OHVT-170C (-4C)	300 - 345	M16	350	2856	100/130	30/40/50	345

Raychem Outdoor Terminations OHVT-245C

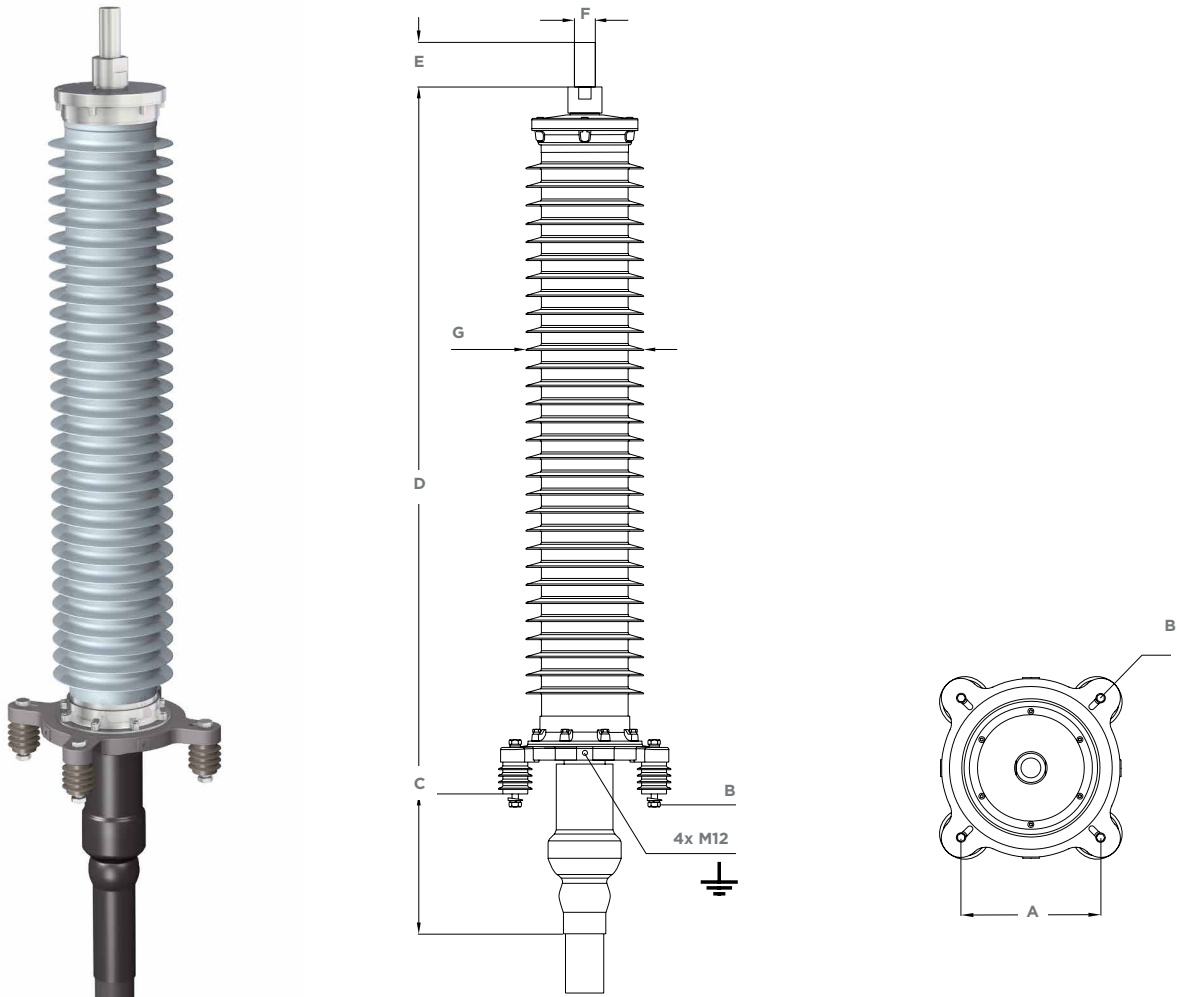

Technical data

Product description	Conductor cross section (mm ²)	Diameter over cable insulation (prepared) (mm)	Max. diameter over outer cable sheath (mm)	Minimal creepage distance (mm)
OHVT-245C (-2A)	300 - 2500	77 - 11	150	5161
OHVT-245C (-3A)	300 - 2500	77 - 119	150	5605
OHVT-245C (-4A)	300 - 2500	77 - 119	150	6160
OHVT-245C (-4B)	300 - 2500	77 - 119	150	8401
OHVT-245C (-4C)	300 - 2500	77 - 119	150	10171

Dimensions

Product description	A (mm)	B (mm)	C (mm)	D (mm)	E (mm)	F (mm)	G (mm)
OHVT-245C (-2A)	430 - 550	M16	350	2564	100/130	50/60	402
OHVT-245C (-3A)	430 - 550	M16	350	2744	100/130	50/60	402
OHVT-245C (-4A)	430 - 550	M16	350	2969	100/130	50/60	402
OHVT-245C (-4B)	430 - 550	M16	350	2777	100/130	50/60	402
OHVT-245C (-4C)	430 - 550	M16	350	3257	100/130	50/60	402

Raychem Outdoor Terminations OHVT-P (Porcelain)

APPLICATION

- The termination is designed for voltage classes up to 245 kV and to operate under severe environmental conditions. Polymeric insulated cables of various designs can be adopted with respect to shielding and metal sheath

FEATURES

- Well-proven porcelain housing
- Pre-fabricated and factory-tested Silicone-rubber stress cone
- Torque-controlled conductor bolt
- H/S components used for sealing
- No special tools required to install the termination
- Silicone-oil filling without preheating
- Insulated base plate for sectionalization
- Fittings made of corrosion resistant alloy
- Type tested according to IEC 60840 and IEC 62067 standards

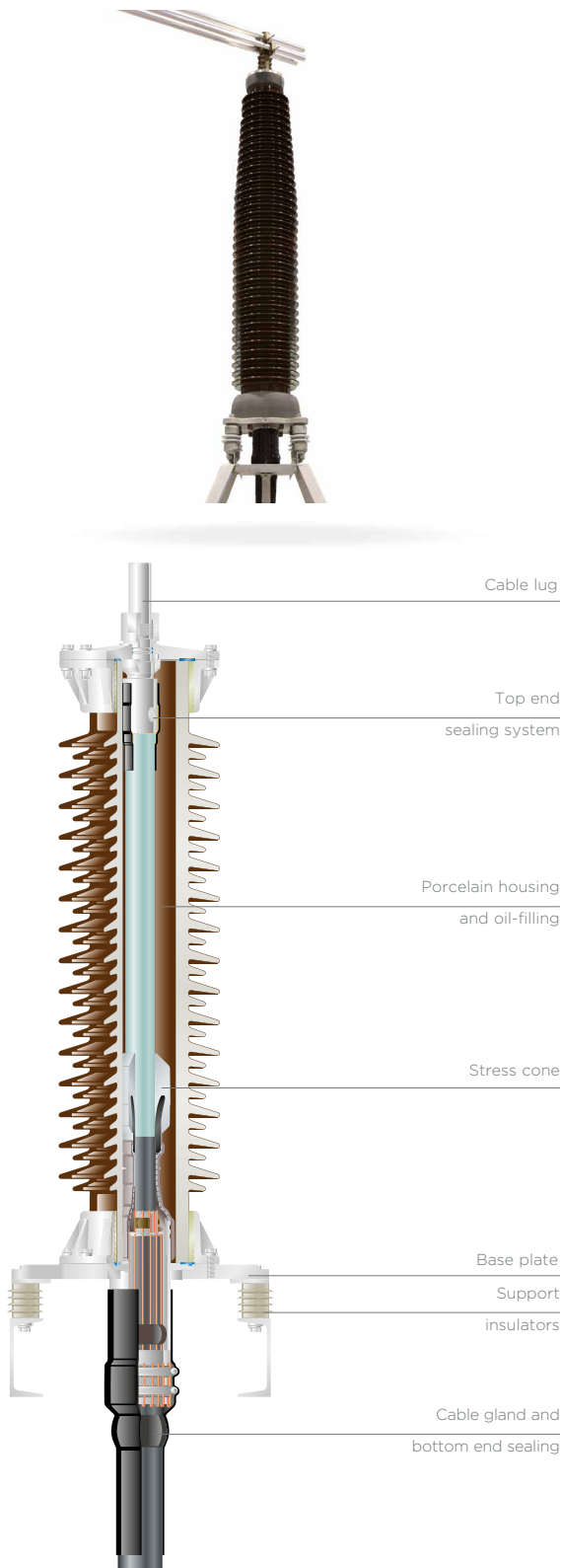

Max. operating voltage U_m (kV)	72.5	123	145	245
Standards	IEC 60840 IEC 60815	IEC 60840 IEC 60815	IEC 60840 IEC 60815	IEC 62067 IEC 60815
Rated voltage U (kV)	60 - 69	110 - 115	132 - 138	220 - 230
Rated lightning impulse withstand voltage (BIL) (kV)	325	550	650	1050

Raychem Outdoor Terminations OHVT-72P

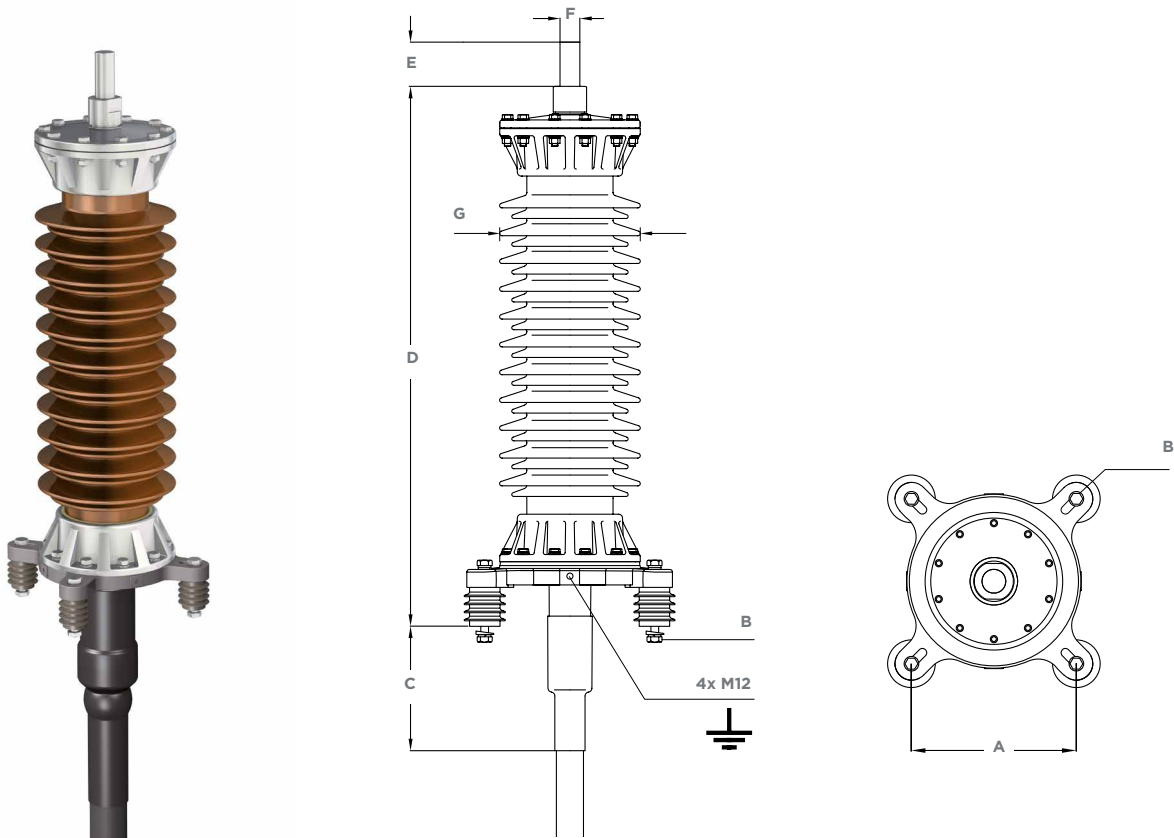

Technical data

Product description	Conductor cross section (mm ²)	Diameter over cable insulation (prepared) (mm)	Max. diameter over outer cable sheath (mm)	Minimal creepage distance (mm)
OHVT-72P (-2A)	95 - 1200	34 - 74	110	2350

Dimensions

Product description	A (mm)	B (mm)	C (mm)	D (mm)	E (mm)	F (mm)	G (mm)
OHVT-72P (-2A)	300 - 345	M16	350	1245	100/130	30/40/50	360

Raychem Outdoor Terminations OHVT-123P

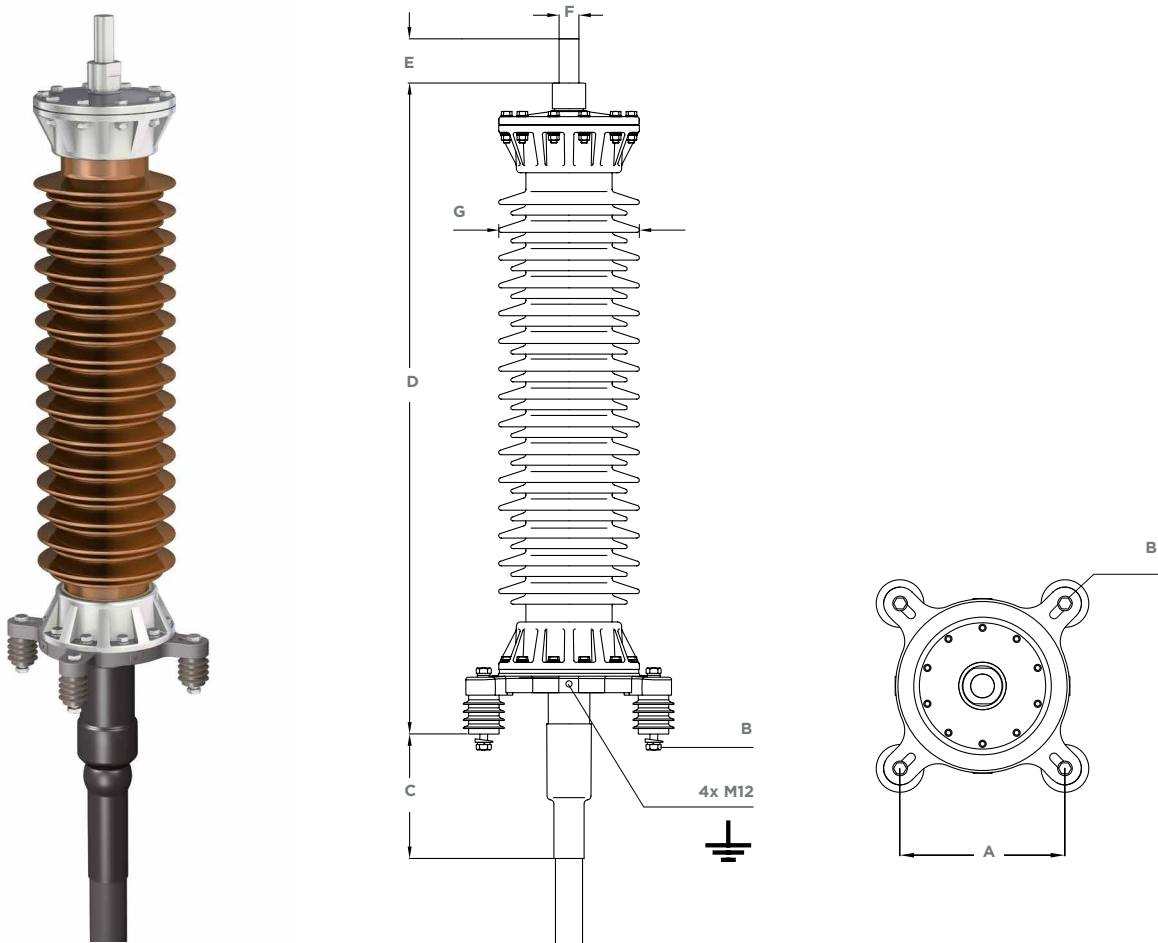

High Voltage Terminations

Technical data

Product description	Conductor cross section (mm ²)	Diameter over cable insulation (prepared) (mm)	Max. diameter over outer cable sheath (mm)	Minimal creepage distance (mm)
OHVT-123P (-4B)	95 - 1200	34 - 74	110	3910

Dimensions

Product description	A (mm)	B (mm)	C (mm)	D (mm)	E (mm)	F (mm)	G (mm)
OHVT-123P (-4B)	300 - 345	M16	350	1830	100/130	30/40/50	385

Raychem Outdoor Terminations OHVT-145P

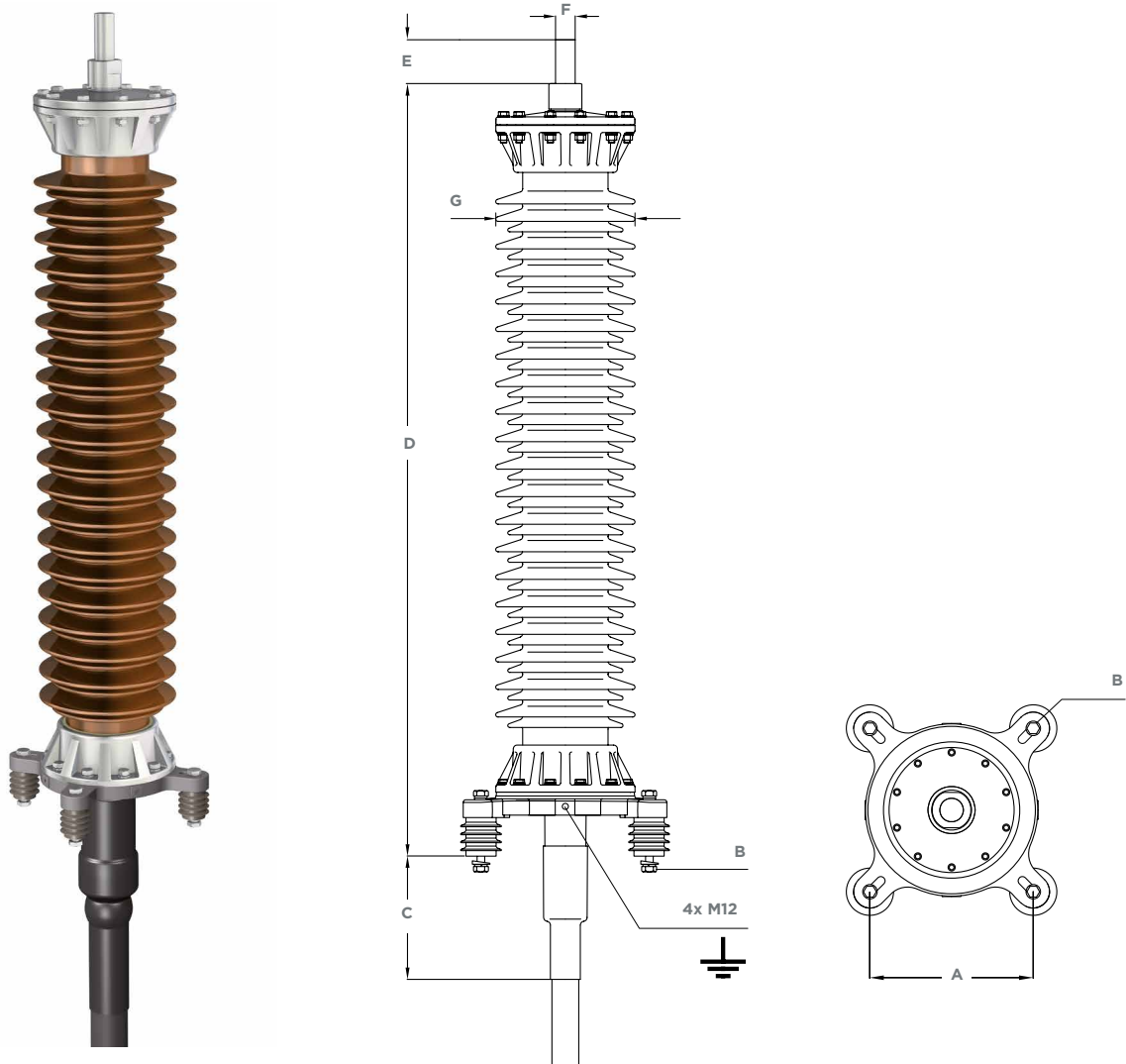

Technical data

Product description	Conductor cross section (mm ²)	Diameter over cable insulation (prepared) (mm)	Max. diameter over outer cable sheath (mm)	Minimal creepage distance (mm)
OHVT-145P (-4A)	95 - 1200	34 - 74	110	4300

Dimensions

Product description	A (mm)	B (mm)	C (mm)	D (mm)	E (mm)	F (mm)	G (mm)
OHVT-72P (-2A)	300 - 345	M16	350	2046	100/130	30/40/50	360

Raychem Outdoor Terminations OHVT-245P

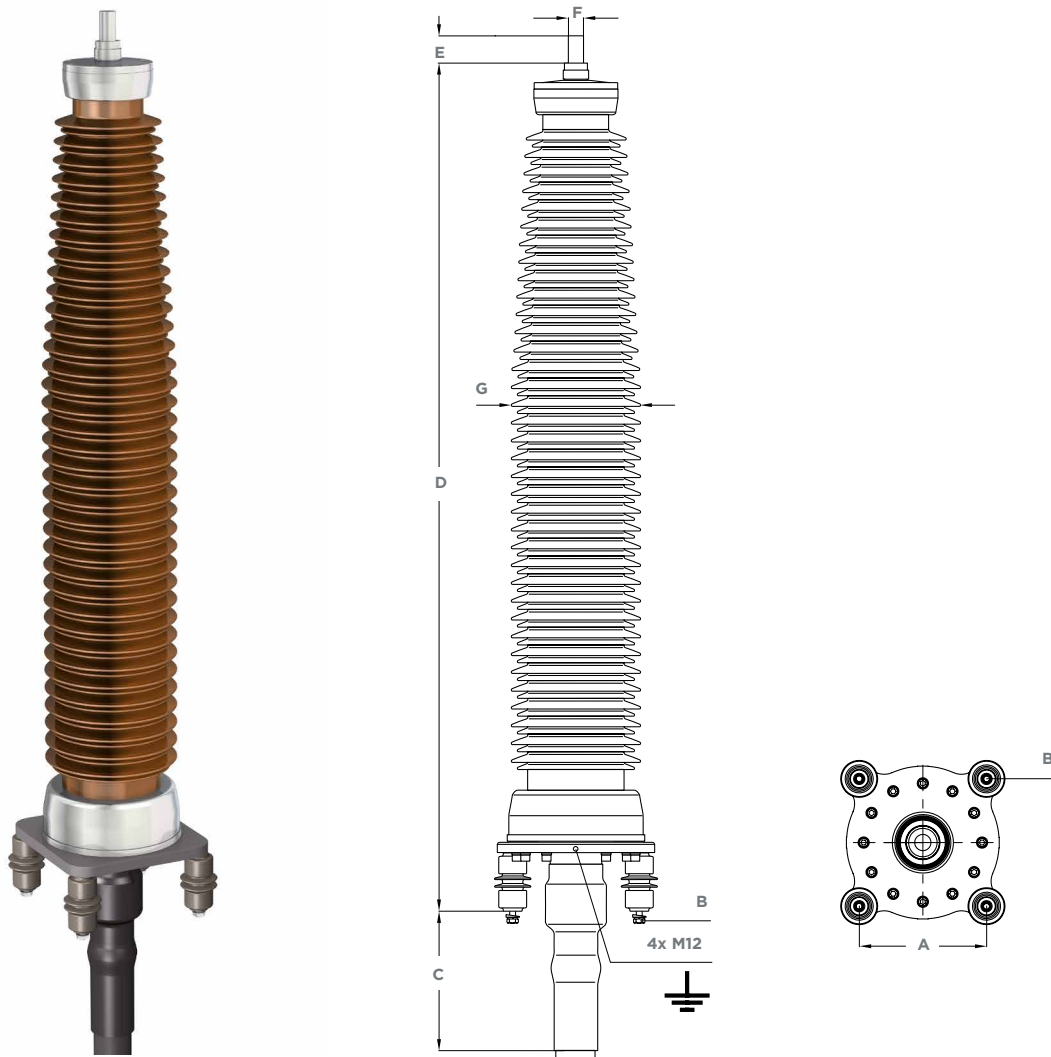

High Voltage Terminations

Technical data

Product description	Conductor cross section (mm ²)	Diameter over cable insulation (prepared) (mm)	Max. diameter over outer cable sheath (mm)	Minimal creepage distance (mm)
OHVT-245P (-1A)	300 - 2000	71 - 119	170	9100

Dimensions

Product description	A (mm)	B (mm)	C (mm)	D (mm)	E (mm)	F (mm)	G (mm)
OHVT-245P (-1A)	500	M24	550	3356	100/130	50/60	514



Raychem Dry Outdoor Terminations (plugable) OHVT-D

APPLICATION

- The dry self-supporting termination is designed for voltage class 145 kV and operation under severe environmental conditions. It is free from any insulating liquid or gel. Polymeric insulated cables of various designs can be adopted with respect to shielding and metal sheath. The termination is easily separable and consists of a plug-in part and an epoxy resin insulator protected with a directly moulded silicone shed housing. Due to the short cable cut-back dimensions of the plug-in, the time required to install the termination is very short and can be further reduced by pre-installing the plug-in on the shop floor. The plug-in is similar to the plug-in used with our dry switchgear/transformer termination

FEATURES

- Dry interface, no oil-filling
- Self-supporting
- Pre-fabricated and factory tested silicone-rubber stress cone
- Torque-controlled multi-contact conductor bolt
- Fast and simple installation combining GIS plug-in technology with polymeric insulators
- No special tools required to install the termination
- Insulated cable gland for sectionalization
- Type tested according to IEC 60840

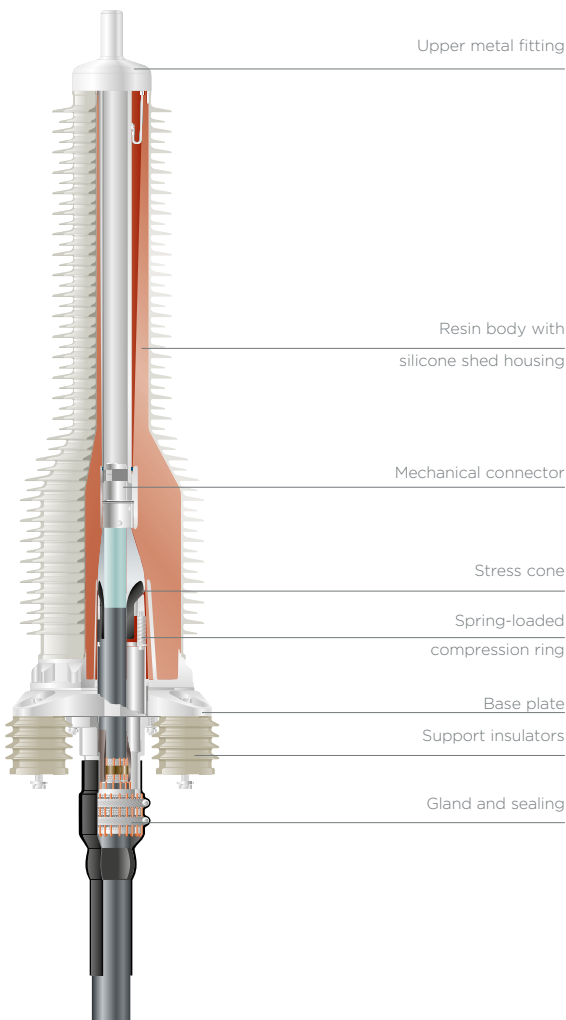

Max. operating voltage U_m (kV)	123	145
Standards	IEC 60840 IEC 60815	IEC 60840 IEC 60815
Rated voltage U (kV)	110 - 115	132 - 138
Rated lightning impulse withstand voltage (BIL) (kV)	550	650

Raychem Dry Outdoor Terminations (plugable) OHVT-D

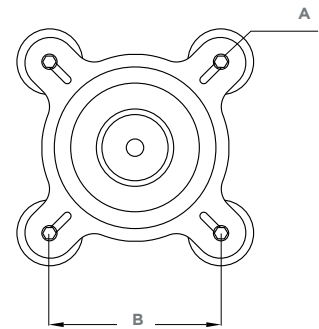
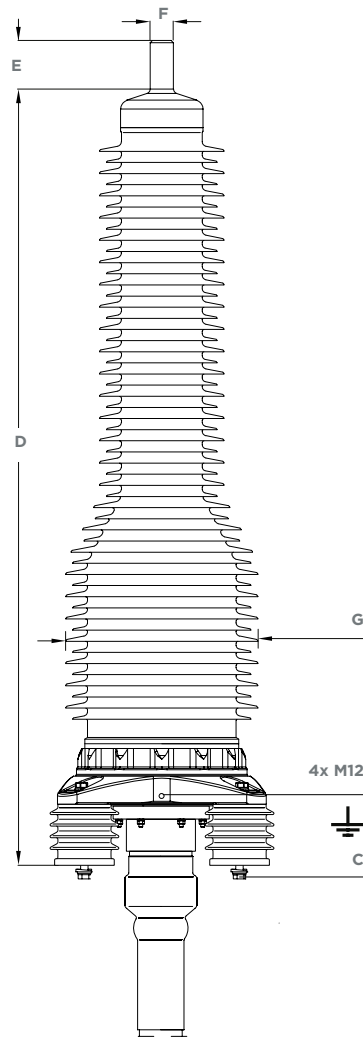

High Voltage Terminations

Technical data

Product description	Conductor cross section (mm ²)	Diameter over cable insulation (prepared) (mm)	Max. diameter over outer cable sheath (mm)	Minimal creepage distance (mm)
OHVT-145D	95 - 1200	34 - 78	99	4680

Dimensions

Product description	A (mm)	B (mm)	C (mm)	D (mm)	E (mm)	F (mm)	G (mm)
OHVT-145D	450	345	M16	1783	100	50	410

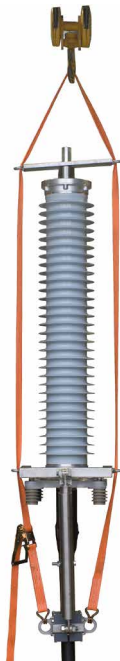

Arcing Horn for Outdoor Terminations OHVT

APPLICATION

- The arcing horns are made to protect the insulators from damage during a flashover. In case of overvoltages, the horns provide a separate breakdown path through the air and keep the flashover from the insulator surface away. As a result of this, the probability of insulator damage by overvoltage is reduced dramatically. The gap length can be adjusted so that the overvoltage withstand-level is variable

FEATURES

- Easy installation
- Various flashover lengths available
- No contact to the grounding system of the termination and power cable for isolated operation
- May be used for porcelain and composite insulators
- Special designs on request

Lifting Device for Outdoor Terminations OHVT

APPLICATION

- This lifting device is designed for lifting the installed termination, including the cable, to high positioned installation sites

FEATURES

- Comfortable and safe installation of the termination on the ground
- Designed to lift the complete installed and oil filled termination with cable
- Easy placement and mounting onto the rack on the pylon
- Applicable for all TE Connectivity terminations up to 170 kV
- Adjustable to all common cable sizes up to a diameter over cable sheath of 110 mm
- Easy assembling and handling
- Entire pulling force is applied to the cable only; no mechanical stress is applied to the termination
- Lifting slings and shackles are not included in the kit, because of their yearly safety check regulations
- Maximum lifting weight 500 kg



Oil Drain Flange for Outdoor Terminations

APPLICATION

- The oil drain flange is being used for easy access to the oil inside of the terminations after installation. This part allows to release some oil for quality check of the oil (e.g. moisture content, dielectric breakdown strength, etc.) if needed. But also in case of a temporary use of an oil filled termination, the incorporated oil can be released through this component so that a disassembling of the termination can be done in a clean way. The oil drain flange is installed between hollow core insulator and base plate

High Voltage Terminations



Fibre-Optic Add-On Kit for Outdoor Terminations

APPLICATION

- The Raychem fibre-optic add-on kit is designed to connect the glass fibres integrated in HV cables. The kit includes all components required to seal the cable jacket and the fibre-optic outlet securely and to protect the sensitive optical fibres that are housed inside the steel pipes
- The standard add-on kit is suitable for connecting two individual steel pipes each with a maximum of 24 optical fibres

FEATURES

- Gel-sealing technology ensures reliable outdoor operation
- Enhanced fibre management
- The splice box is easy to open and close without the use of special tools
- The kits are available for Raychem outdoor terminations





Chapter II

High Voltage Dry Plug-In Terminations

Dry Plug-In Switchgear
and Transformer Terminations 32

Add-On Kits for Dry Plug-In Switchgear
and Transformer Terminations PHVS & PHVT 41

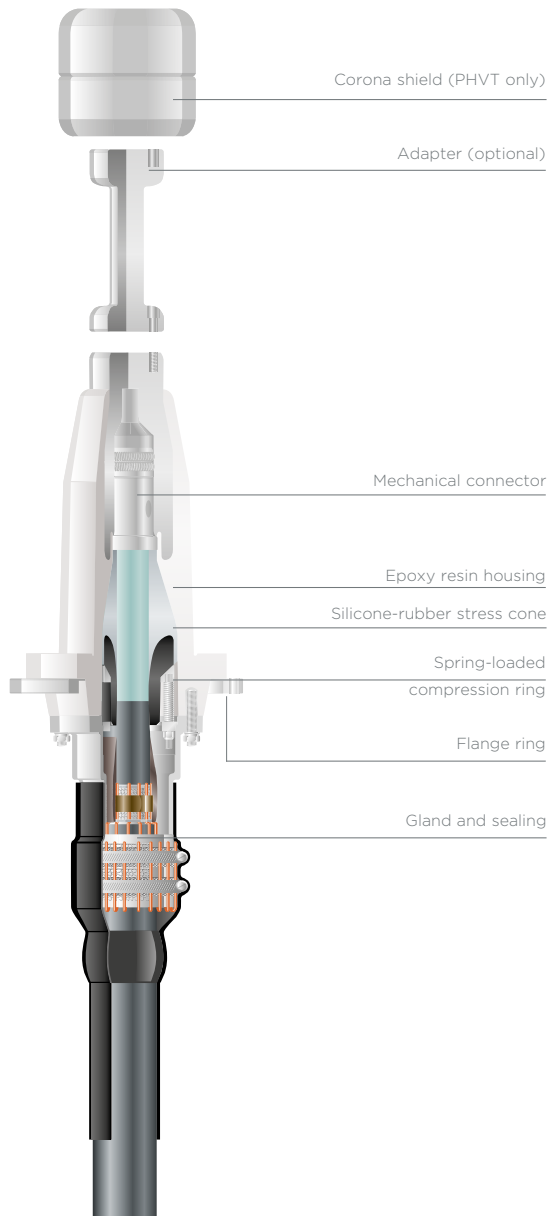

Raychem Dry Compact Switchgear & Transformer Terminations PHVS & PHVT

APPLICATION

- The dry compact switchgear termination for voltage classes up to 245 kV is designed to be installed in cable entry housings of gas-insulated switchgear (GIS). It complies with IEC 62271-209 standard, which essentially specifies the interfaces between the termination and the switchgear. Therefore, the termination will fit into all GIS that comply with IEC 62271-209. Adapters are available to match the dimensions of wet (oil-filled) type terminations, and older designs specified in IEC 60859. The termination operates in SF6 but also in insulating liquids like transformer oil. A corona shield at the top of the termination then provides the necessary shielding for the terminal. The termination is easily separable and consists of a plug-in part and an epoxy resin insulator. The insulator can be installed by the GIS or transformer manufacturer directly at the factory, saving installation time on-site and reducing the risk of contamination of the cable entry housing

FEATURES

- Dry interfaces, no oil-filling
- Dimensions comply with IEC 62271-209
- Pressure-tight resin housing
- Operates in SF6 and insulating liquids
- Pre-fabricated and factory-tested silicone-rubber stress cone
- Torque-controlled or wedge-type multi-contact conductor bolt
- No special tools required to install the termination
- Insulated cable gland for sectionalization
- Type tested according to IEC 60840, IEC 62067 and IEC 62271-209 standards

Max. operating voltage U_m (kV)	72,5	123	145	170	245
Standards	IEC 60840 IEC 62271-209	IEC 60840 IEC 62271-209	IEC 60840 IEC 62271-209	IEC 60840 IEC 62271-209	IEC 62067 IEC 62271-209
Rated voltage U (kV)	60 - 69	110 - 115	132 - 138	150 - 161	220 - 230
Rated lightning impulse withstand voltage (BIL) (kV)	325	550	650	750	1050

Raychem Dry Compact Switchgear Terminations PHVS-72

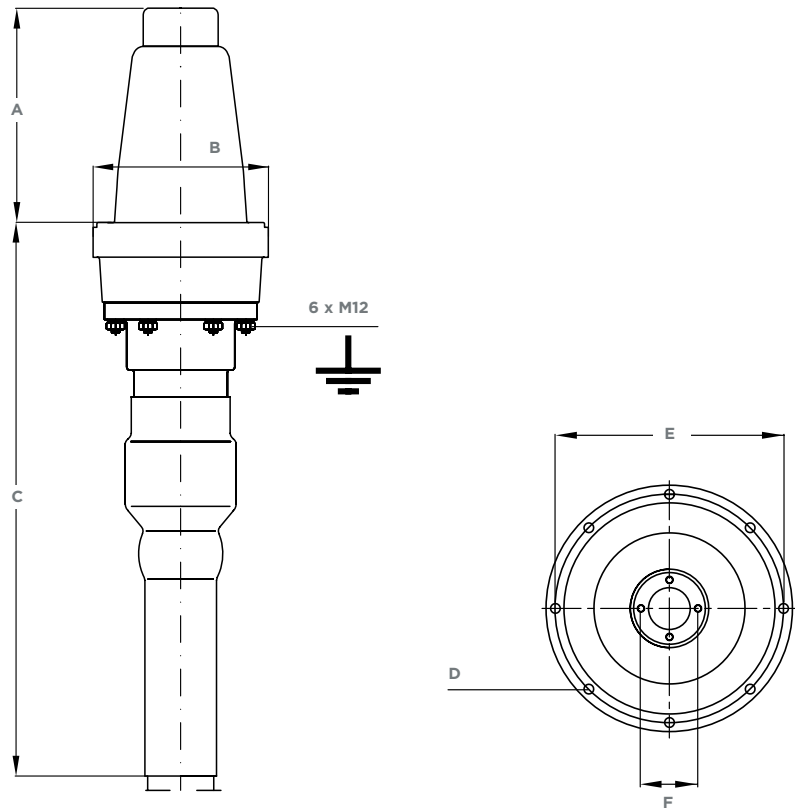

High Voltage Dry Plug-In Terminations

Technical data

Product description	Conductor cross section (mm ²)	Diameter over cable insulation (prepared) (mm)	Max. diameter over outer cable sheath (mm)	Minimal creepage distance (mm)
PHVS-72	95 - 2000	34 - 78	120	255

Dimensions

Product description	A (mm)	B (mm)	C (mm)	D (mm)	E (mm)	F (mm)
PHVS-72	310	255	800	8 x 12	270	80

Raychem Dry Compact Switchgear Terminations PHVS-145

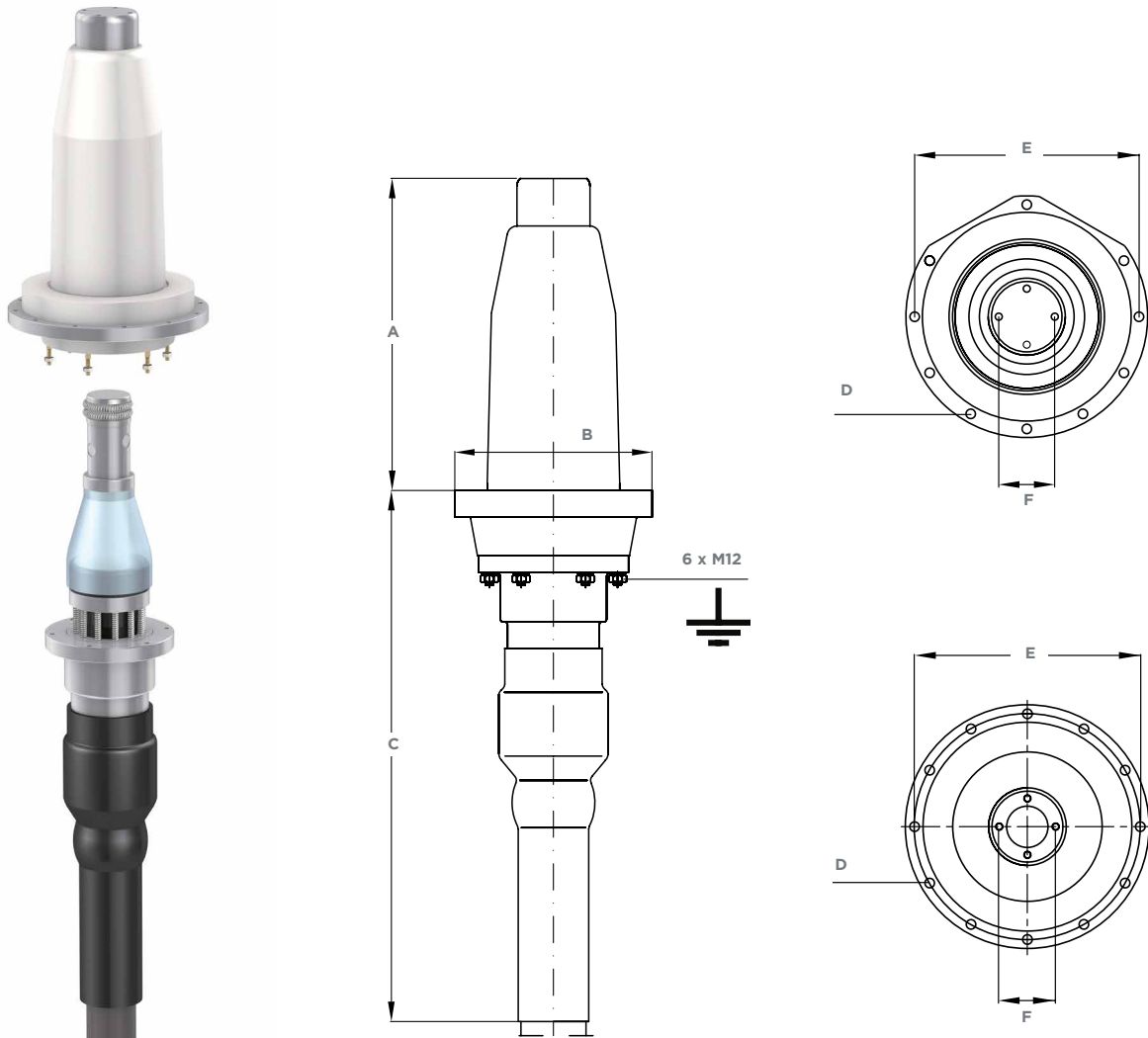

Technical data

Product description	Conductor cross section (mm ²)	Diameter over cable insulation (prepared) (mm)	Max. diameter over outer cable sheath (mm)	Minimal creepage distance (mm)
PHVS-145	95 - 1200	34 - 78	120	414
PHVS-145	1200 - 2500	73 - 108	135	414

Dimensions

Product description	A (mm)	B (mm)	C (mm)	D (mm)	E (mm)	F (mm)
PHVS-145	470	297	800	12 x 13.5	320	80

Raychem Dry Compact Switchgear Terminations PHVS-170

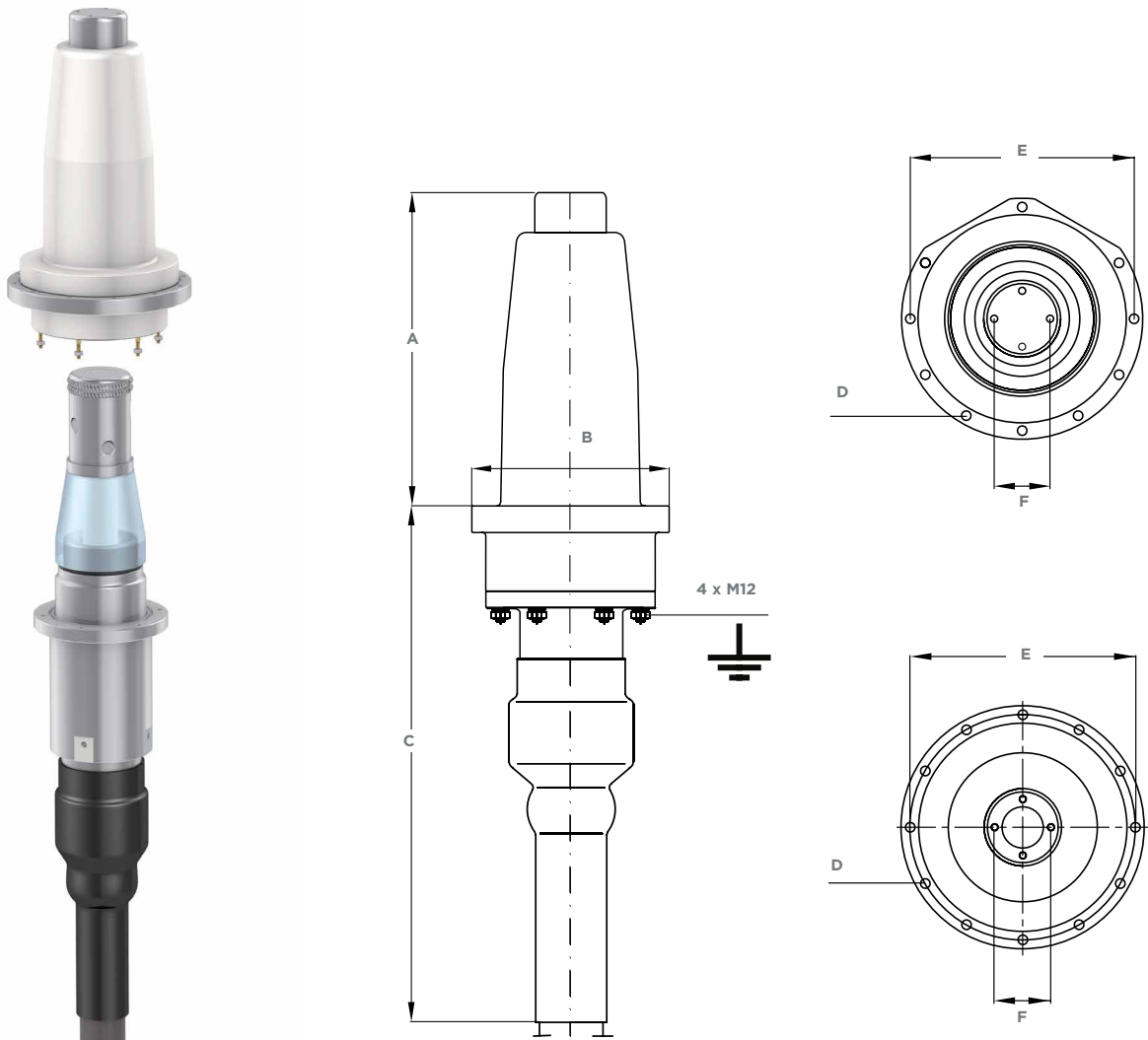

High Voltage
Dry Plug-In
Terminations

Technical data

Product description	Conductor cross section (mm ²)	Diameter over cable insulation (prepared) (mm)	Max. diameter over outer cable sheath (mm)	Minimal creepage distance (mm)
PHVS-170	1000 - 2500	73 - 108	135	414

Dimensions

Product description	A (mm)	B (mm)	C (mm)	D (mm)	E (mm)	F (mm)
PHVS-170	470	298	800	12 x 13.5	320	80

Raychem Dry Compact Switchgear Terminations PHVS-245

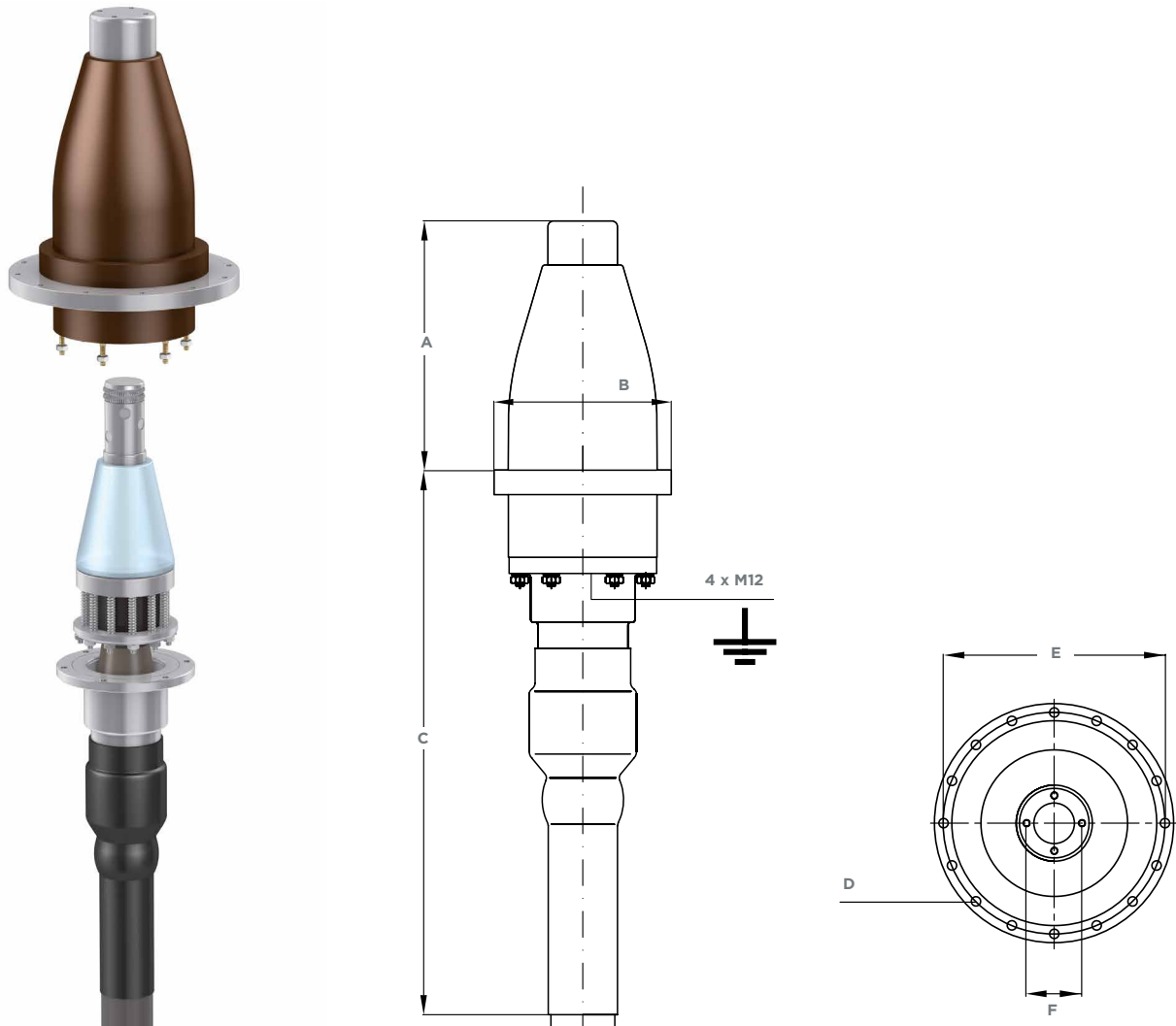

Technical data

Product description	Conductor cross section (mm ²)	Diameter over cable insulation (prepared) (mm)	Max. diameter over outer cable sheath (mm)	Minimal creepage distance (mm)
PHVS-245	300 - 2500	77 - 119	150	519

Dimensions

Product description	A (mm)	B (mm)	C (mm)	D (mm)	E (mm)	F (mm)
PHVS-245	620	454	860	16 X 13,5	475	110

Raychem Dry Compact Transformer Terminations PHVT-72

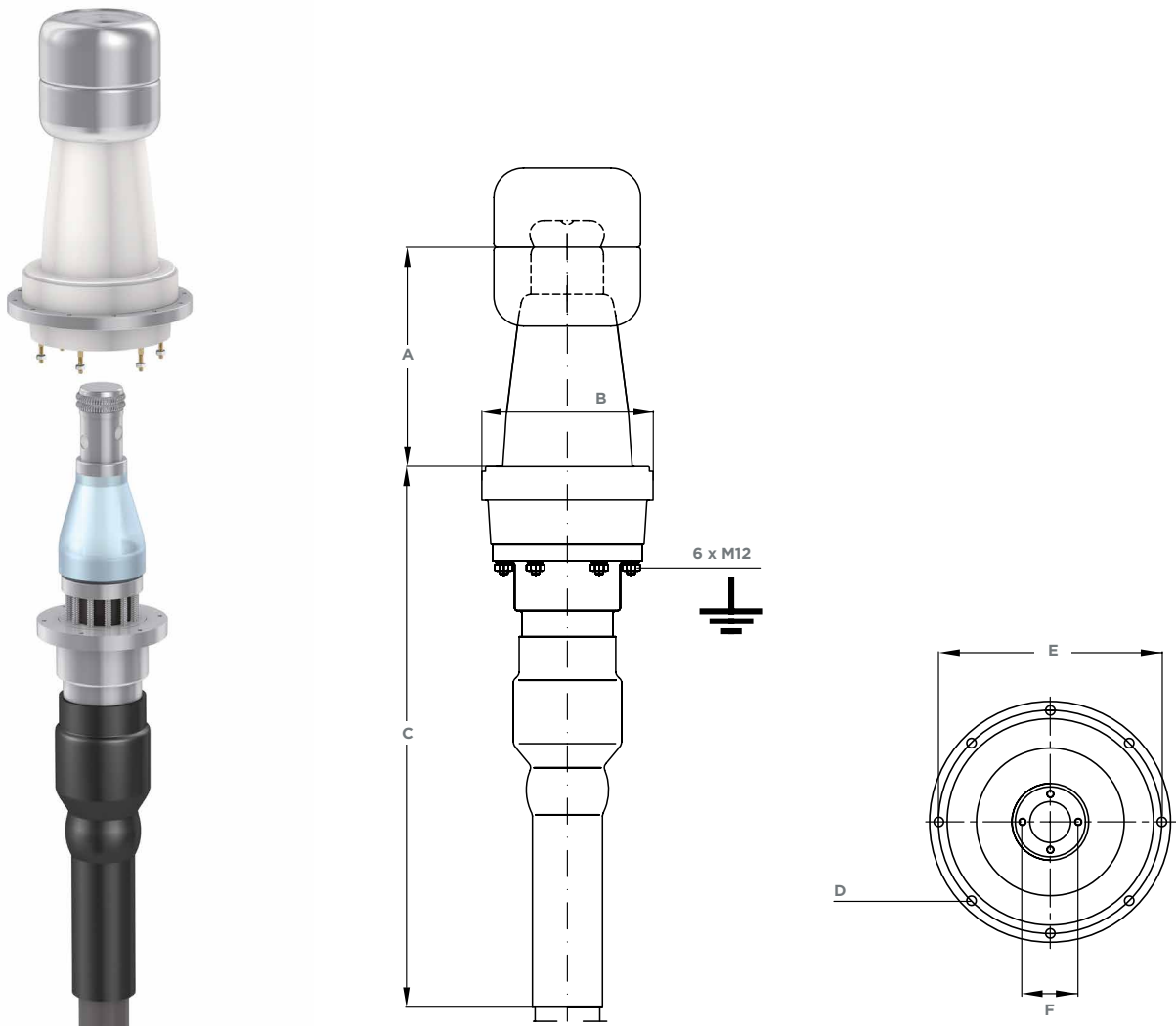
High Voltage
Dry Plug-In
Terminations

Technical data

Product description	Conductor cross section (mm ²)	Diameter over cable insulation (prepared) (mm)	Max. diameter over outer cable sheath (mm)	Minimal creepage distance (mm)
PHVT-72	95 - 2000	34 - 78	120	255

Dimensions

Product description	A (mm)	B (mm)	C (mm)	D (mm)	E (mm)	F (mm)
PHVT-72	310	255	800	8 X 12	270	80

Raychem Dry Compact Transformer Terminations PHVT-145

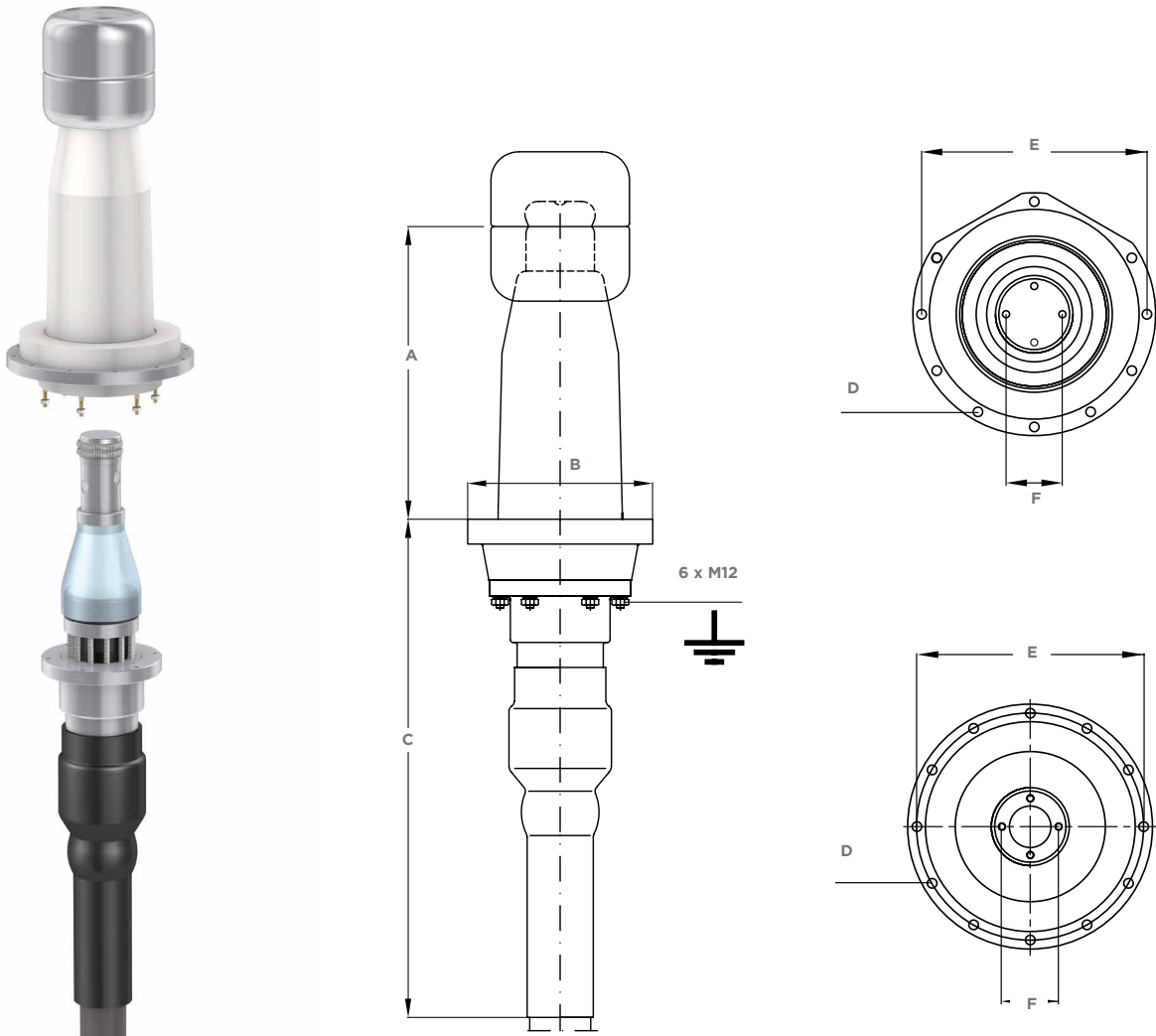

Technical data

Product description	Conductor cross section (mm ²)	Diameter over cable insulation (prepared) (mm)	Max. diameter over outer cable sheath (mm)	Minimal creepage distance (mm)
PHVT-145	95 - 1200	34 - 78	120	414
PHVT-145	1200 - 2500	73 - 108	135	414

Dimensions

Product description	A (mm)	B (mm)	C (mm)	D (mm)	E (mm)	F (mm)
PHVT-145	470	297	800	12 x 13.5	320	80

Raychem Dry Compact Transformer Terminations PHVT-170

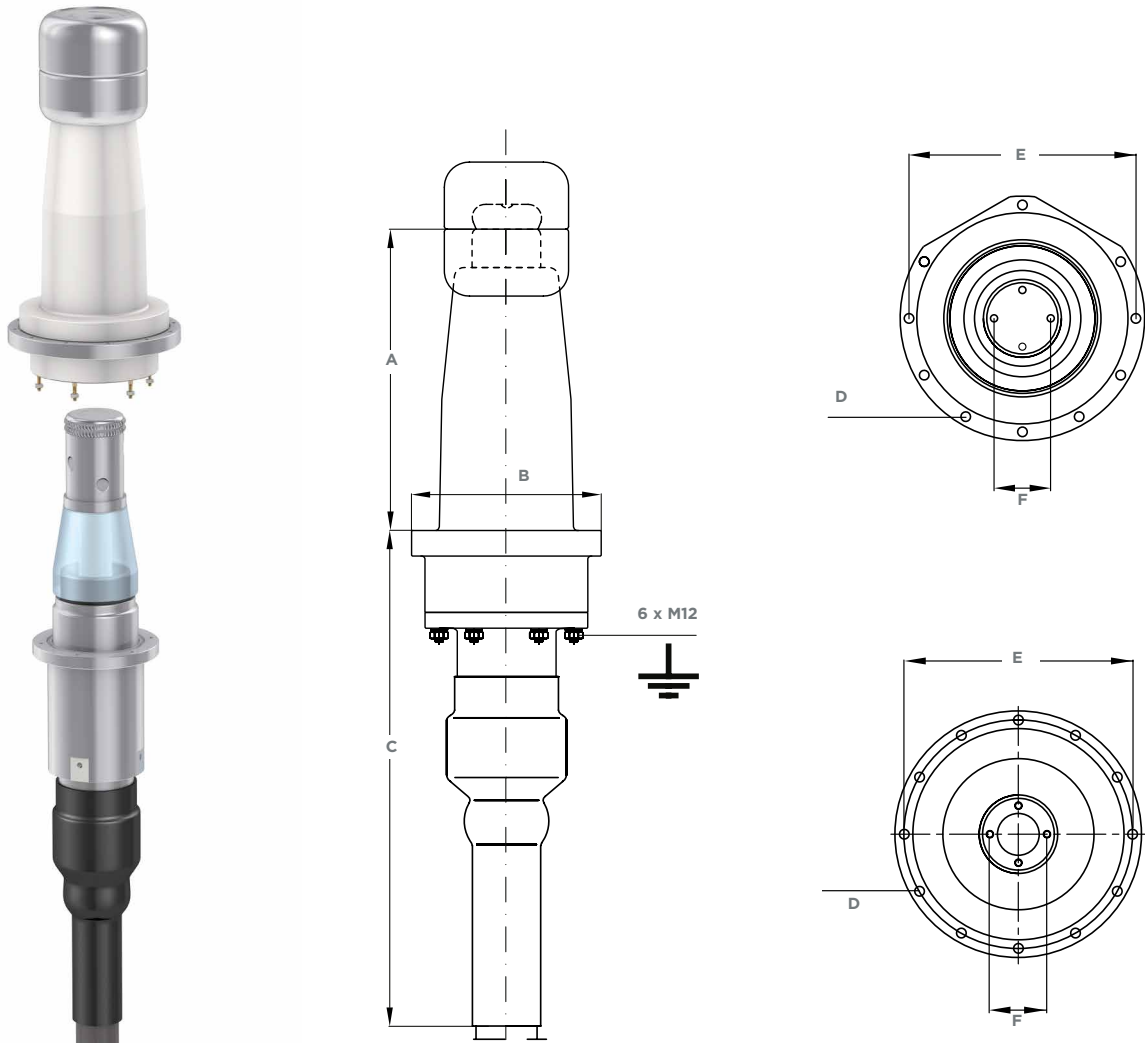

High Voltage
Dry Plug-In
Terminations

Technical data

Product description	Conductor cross section (mm ²)	Diameter over cable insulation (prepared) (mm)	Max. diameter over outer cable sheath (mm)	Minimal creepage distance (mm)
PHVT-170	1000 - 2500	73 - 108	135	414

Dimensions

Product description	A (mm)	B (mm)	C (mm)	D (mm)	E (mm)	F (mm)
PHVT-170	470	298	800	12 x 13.5	320	80

Raychem Dry Compact Transformer Terminations PHVT-245

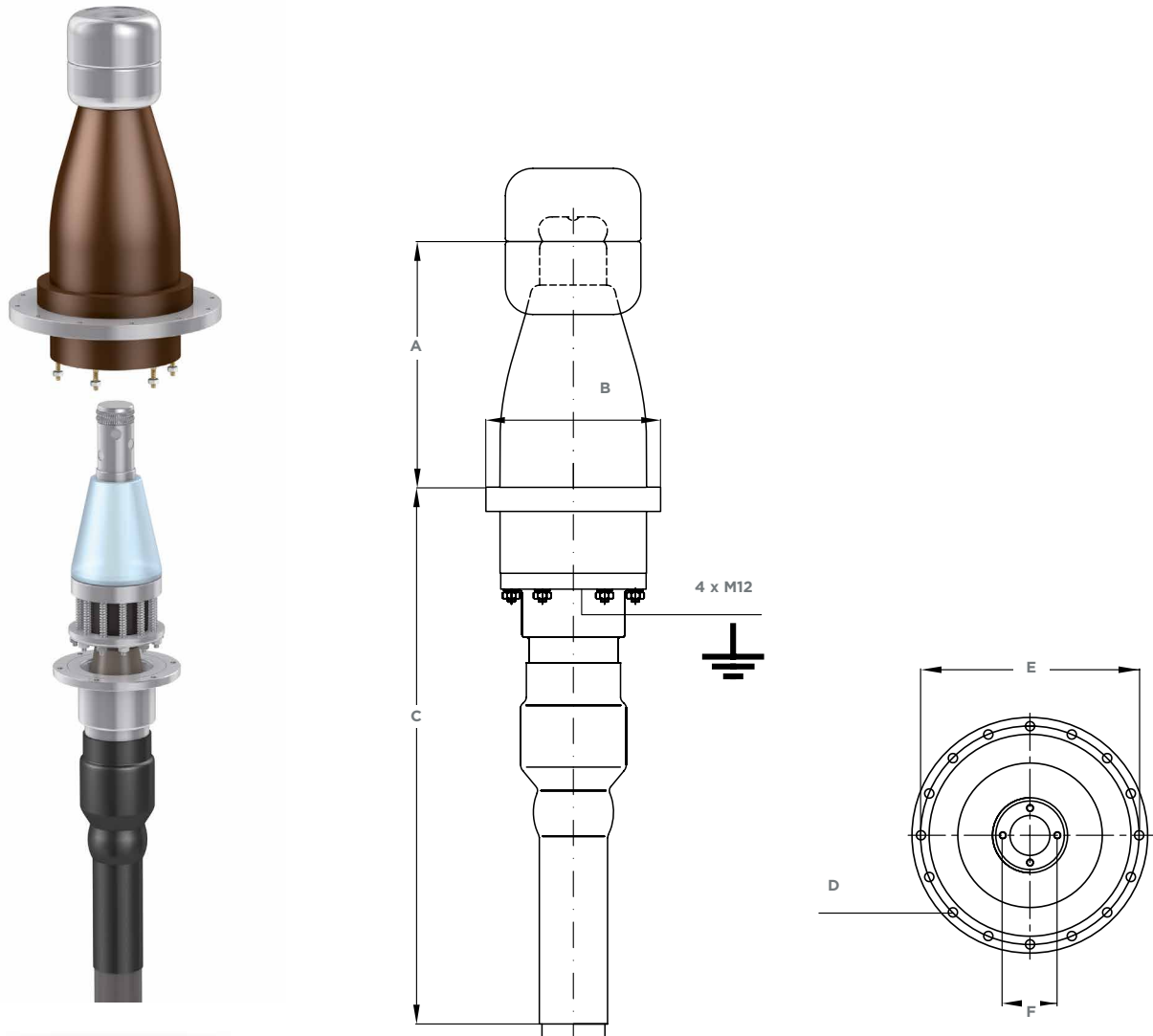

Technical data

Product description	Conductor cross section (mm ²)	Diameter over cable insulation (prepared) (mm)	Max. diameter over outer cable sheath (mm)	Minimal creepage distance (mm)
PHVT-245	300 - 2500	77 - 119	150	519

Dimensions

Product description	A (mm)	B (mm)	C (mm)	D (mm)	E (mm)	F (mm)
PHVT-245	620	454	860	16 X 13,5	475	110



Blind Plug for Dry Plug-In Switchgear and Transformer Terminations

APPLICATION

- Suitable for use when the switchgear is under operation without a cable connection. The blind plug (also known as dead end plug or dummy plug) is used to close the socket of the cable entry housing

FEATURES

- Voltage proof and can be used for continuous operation at nominal voltage
- Easy installation - similar to standard plug in
- Blind plug is removable and can be used as a temporary solution until the cable is connected
- Blind plug is re-usable
- Type tested according to the IEC 60840 standard

High Voltage Dry Plug-In Terminations



Test Plate for Dry Plug-In Switchgear and Transformer Terminations

APPLICATION

- Suitable for use where the switchgear needs to be tested. The plate is an adapter to pressurize the inner part of the insulator with SF6.

FEATURES

- Pressure tested
- Suitable manometer available
- Re-useable

Accessories for Dry Plug-In Switchgear and Transformer Terminations

Our product portfolio includes not only the high voltage cable accessories but also their add-on accessories. The range shown below doesn't cover all available accessories. Special components can be made on request.

Portfolio:

- Protection cover
- Adapter
- Cable reel
- Special connectors



Fibre-Optic Add-On Kit for Terminations

APPLICATION

- The Raychem fibre-optic add-on kit is designed to connect the glass fibres integrated in HV cables. The kit includes all components required to seal the cable jacket and the fibre-optic outlet securely and to protect the sensitive optical fibres that are housed inside the steel pipes
- The standard add-on kit is suitable for connecting two individual steel pipes each with a maximum of 24 optical fibres

FEATURES

- Gel-sealing technology ensures reliable outdoor operation
- Enhanced fibre management
- The splice box is easy to open and close without the use of special tools
- The kits are available for Raychem equipment terminations



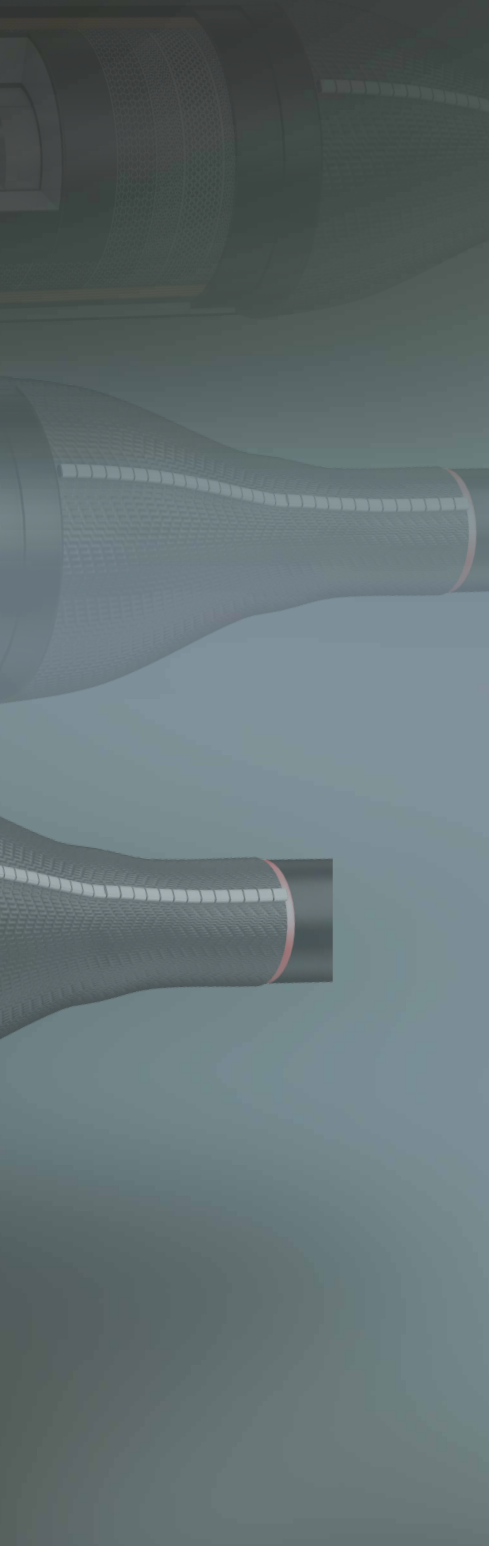

Chapter III High voltage cable joints

Heat-Shrinkable Joint EHVS-H	46
One Piece Joint EHVS-S.....	49
Three Piece Joint EHVS-T	52
Fibre-Optic Add-On Kit for HV Cable Joints	55

Raychem Heat-Shrinkable Joints for Polymeric Cables 52/72 kV

APPLICATION

- Polymeric insulated cables of various designs can be adapted with respect to shielding and metal sheath. Our heat shrink accessories have been used by utilities and industrial companies around the world for more than 50 years. This ongoing field experience has us a leader in materials science and technology for high voltage applications. Our materials technology is at the core of the development of our heat-shrinkable joints. The materials, used in TE Connectivity Raychem cable accessories, have been extensively optimized with respect to product design and function, manufacturing, and expected service environments

FEATURES

- Compact and modular design
- Heat-shrinkable stress control sleeves
- Torque-controlled connector
- Joint fits on all polymeric cable constructions
- Proven shield continuity concept
- Short cut-back dimension
- Cable size transition possible
- Water and corrosion-resistant
- Easy and fast to install
- No special or expensive tools required
- Lightweight components
- Unlimited storage life-time under normal conditions
- Reduced waste for disposal
- Wide installed base at international customers

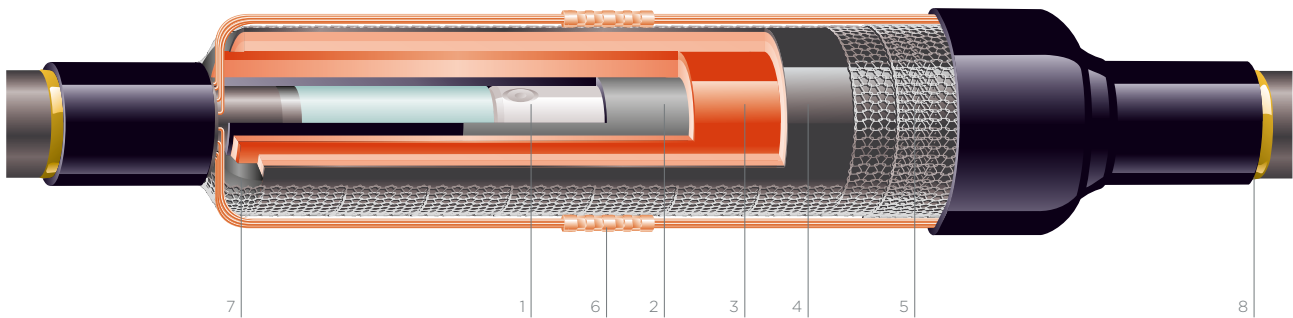

- 1 Mechanical connector
- 2 Electrical stress control tube
- 3 Insulating tubing
- 4 Screened insulating tubing
- 5 Copper mesh
- 6 Solderless shield connection
- 7 Sealant/mastic
- 8 Outer protection with integrated moisture barrier

Max. operating voltage U_m (kV)	52	72.5
Standards	IEC 60840	IEC 60840
Rated voltage U (kV)	45 - 47	60 - 69
Rated lightning impulse withstand voltage (BIL) (kV)	250	325



EHVS-52H



EHVS-72H

Technical data

Product description	Conductor cross section (mm ²)	Diameter over cable insulation (prepared) (mm)	Diameter over outer cable sheath (mm)	Length (mm)	Diameter (mm)	Screen treatment
EHVS-52H	95 - 2500	30 - 86	50 - 100	1350	130	Inline / shield break / grounded
EHVS-72H	95 - 2500	30 - 86	50 - 100	1350	130	Inline / shield break / grounded

Raychem One Piece Joint up to 245 kV

APPLICATION

- The joint is a pre-fabricated one-piece design for voltage classes up to 245 kV. Polymeric insulated cables of various designs can be adapted with respect to shielding and metal sheath. The silicone rubber joint body with integrated geometrical stress control, provides proven electrical function. The joint components combine electrical performance, stress control and moisture sealing to provide the important functions required for all high voltage products

FEATURES

- Premoulded one-piece joint body
- Torque-controlled connector
- Choice of outer sealing and protection systems
- Joint fits on all polymeric cable constructions
- Proven shield continuity concept
- Factory-tested silicone-rubber body
- Special silicone rubber provides perfect compression force for optimised electrical performance
- Simple assembly
- No tension set of joint body
- Moulded thick outer conductive screen
- Geometrical electrical stress control by moulded conductive deflectors
- Type tested according to IEC 60840, IEC 62067 standards

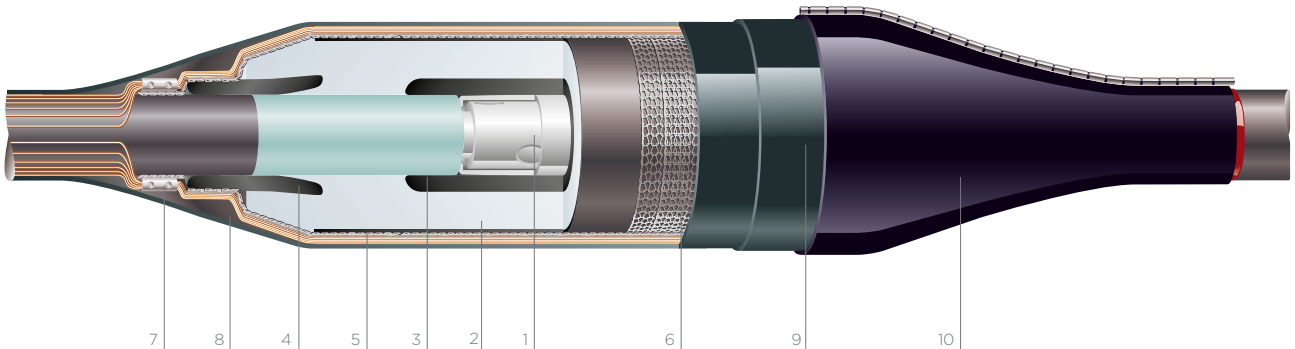

- Mechanical connector
- Silicone rubber body
- Inner electrode/Faraday cage
- Deflector
- Outer screen
- Copper mesh
- Solderless shield connection
- Sealant/mastic
- Insulating tubes
- Outer protection with integrated moisture barrier

Max. operating voltage U_m (kV)	145	245
Standards	IEC 60840	IEC 62067
Rated voltage U (kV)	132 - 138	220 - 230
Rated lightning impulse withstand voltage (BIL) (kV)	650	1050

Raychem One Piece Joint up to 145 kV

Heat-shrink Rejacketing



Product description	Conductor cross section (mm ²)	Diameter over cable insulation (prepared) (mm)	Max over outer cable sheath (mm)	Lenght (mm)	Diameter (mm)	Screen treatment
EHVS-145SW	500 - 2500	52 - 112	145	2400	220	Inline / shield break / grounded

Copper Casing



Product description	Conductor cross section (mm ²)	Diameter over cable insulation (prepared) (mm)	Max over outer cable sheath (mm)	Lenght (mm)	Diameter (mm)	Screen treatment
EHVS-145SC	500 - 2500	52 - 112	145	2400	280	Inline / shield break / grounded

Coffin Box



Product description	Conductor cross section (mm ²)	Diameter over cable insulation (prepared) (mm)	Max over outer cable sheath (mm)	Lenght (mm)	Diameter (mm)	Screen treatment
EHVS-145SB	500 - 2500	52 - 112	145	3000	350	Inline / shield break / grounded

Heavy Duty (Copper Casing and Coffin Box)



Product description	Conductor cross section (mm ²)	Diameter over cable insulation (prepared) (mm)	Max over outer cable sheath (mm)	Lenght (mm)	Diameter (mm)	Screen treatment
EHVS-145SH	500 - 2500	52 - 112	145	3000	350	Inline / shield break / grounded

Raychem One Piece Joint up to 245 kV

Heat-shrink Rejacketing



Product description	Conductor cross section (mm ²)	Diameter over cable insulation (prepared) (mm)	Max over outer cable sheath (mm)	Length (mm)	Diameter (mm)	Screen treatment
EHVS-245SW	300 - 2500	71 - 119	150	2500	310	Inline / shield break / grounded

Copper Casing



Product description	Conductor cross section (mm ²)	Diameter over cable insulation (prepared) (mm)	Max over outer cable sheath (mm)	Length (mm)	Diameter (mm)	Screen treatment
EHVS-245SC	300 - 2500	71 - 119	150	2500	350	Inline / shield break / grounded

Coffin Box



Product description	Conductor cross section (mm ²)	Diameter over cable insulation (prepared) (mm)	Max over outer cable sheath (mm)	Length (mm)	Diameter (mm)	Screen treatment
EHVS-245SB	300 - 2500	71 - 119	150	3500	550	Inline / shield break / grounded

Heavy Duty (Copper Casing and Coffin Box)



Product description	Conductor cross section (mm ²)	Diameter over cable insulation (prepared) (mm)	Max over outer cable sheath (mm)	Length (mm)	Diameter (mm)	Screen treatment
EHVS-245SH	300 - 2500	71 - 119	150	3500	550	Inline / shield break / grounded

Raychem Three Piece Joint up to 170 kV

APPLICATION

- The joint is a pre-fabricated three piece design for voltage classes up to 170 kV. Polymeric insulated cables of various designs can be adapted with respect to shielding and metal sheath. The silicone rubber joint parts with integrated geometrical stress control provides proven electrical function. The joint components combine electrical performance, stress control, and moisture sealing to provide the important functions required for all high voltage products

FEATURES

- Premoulded three piece joint design
- Torque-controlled connector
- Joint fits on all polymeric cable constructions
- Proven shield continuity concept
- Factory-tested silicone rubber bodies
- Special silicone rubber provides perfect compression force for optimized electrical performance
- Short cut-back dimensions
- No special tools required to install the joint
- Cable size transition possible
- No tension set of joint body
- Moulded outer conductive screen
- Geometrical electrical stress control by moulded conductive deflectors
- Type tested according to IEC60840 standards

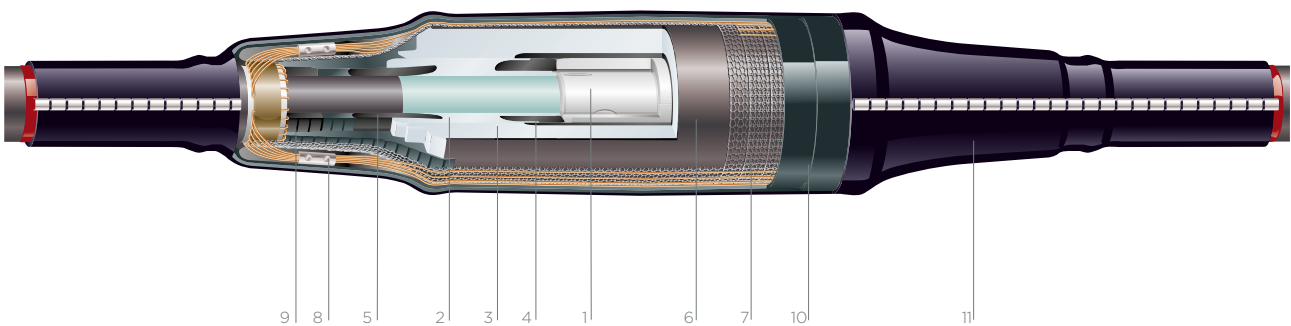

- Mechanical connector
- Silicone rubber adapter body
- Silicone rubber main body
- Inner electrode/Faraday cage
- Deflector
- Outer screen (moulded)
- Copper mesh
- Solderless shield continuity
- Sealant/mastic
- Insulating tubes
- Outer protection with integrated moisture barrier

Max. operating voltage U_m (kV)	145	170
Standards	IEC 60840	IEC 60840
Rated voltage U (kV)	132 - 138	150 - 161
Rated lightning impulse withstand voltage (BIL) (kV)	650	750

Raychem Three Piece Joint up to 145 kV

Heat-shrink Rejacketing



Product description	Conductor cross section (mm ²)	Diameter over cable insulation (prepared) (mm)	Max over outer cable sheath (mm)	Lenght (mm)	Diameter (mm)	Screen treatment
EHVS-145TW	185 - 1600	43 - 83	105	2000	200	Inline / shield break / grounded
EHVS-145TW	1600 - 2500	60 - 110	112	2000	250	Inline / shield break / grounded

Copper Casing



Product description	Conductor cross section (mm ²)	Diameter over cable insulation (prepared) (mm)	Diameter over outer cable sheath (mm)	Lenght (mm)	Diameter (mm)	Screen treatment
EHVS-145TC	185 - 1600	43 - 83	105	2500	250	Inline / shield break / grounded
EHVS-145TC	1600 - 2500	60 - 110	112	2500	250	Inline / shield break / grounded

Coffin Box



Product description	Conductor cross section (mm ²)	Diameter over cable insulation (prepared) (mm)	Diameter over outer cable sheath (mm)	Lenght (mm)	Diameter (mm)	Screen treatment
EHVS-145TB	185 - 1600	43 - 83	105	3000	350	Inline / shield break / grounded
EHVS-145TB	1600 - 2500	60 - 110	112	3000	350	Inline / shield break / grounded

Heavy Duty (Copper Casing and Coffin Box)

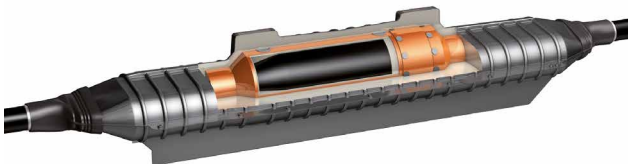

Product description	Conductor cross section (mm ²)	Diameter over cable insulation (prepared) (mm)	Diameter over outer cable sheath (mm)	Lenght (mm)	Diameter (mm)	Screen treatment
EHVS-145TH	185 - 1600	43 - 83	105	3000	350	Inline / shield break / grounded
EHVS-145TH	1600 - 2500	60 - 110	112	3000	350	Inline / shield break / grounded

Raychem Three Piece Joint up to 170 kV

Heat-shrink Rejacketing



Product description	Conductor cross section (mm ²)	Diameter over cable insulation (prepared) (mm)	Max over outer cable sheath (mm)	Lenght (mm)	Diameter (mm)	Screen treatment
EHVS-170TW	240 - 2500	60 - 110	112	2000	250	Inline / shield break / grounded

Copper Casing



Product description	Conductor cross section (mm ²)	Diameter over cable insulation (prepared) (mm)	Max over outer cable sheath (mm)	Lenght (mm)	Diameter (mm)	Screen treatment
EHVS-170TC	240 - 2500	60 - 110	112	2500	300	Inline / shield break / grounded

Coffin Box



Product description	Conductor cross section (mm ²)	Diameter over cable insulation (prepared) (mm)	Max over outer cable sheath (mm)	Lenght (mm)	Diameter (mm)	Screen treatment
EHVS-170TB	240 - 2500	60 - 110	112	3500	450	Inline / shield break / grounded

Heavy Duty (Copper Casing and Coffin Box)



Product description	Conductor cross section (mm ²)	Diameter over cable insulation (prepared) (mm)	Max over outer cable sheath (mm)	Lenght (mm)	Diameter (mm)	Screen treatment
EHVS-170TH	240 - 2500	60 - 110	112	3500	450	Inline / shield break / grounded

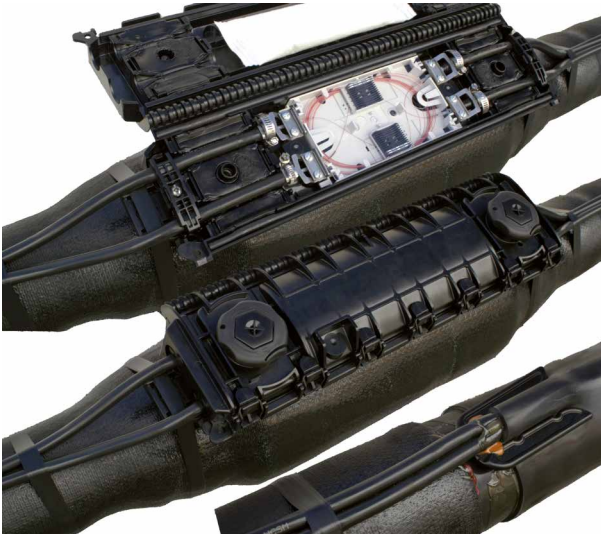

Fibre-Optic Add-On Kit for HV Cable Joints

APPLICATION

- The Raychem fibre-optic add-on kit is designed to connect the glass fibres integrated in HV cables. The kit includes all components required to seal the cable jacket and the fibre-optic outlet securely and to protect the sensitive optical fibres that are housed inside the steel pipes
- The standard add-on kit is suitable for connecting two individual steel pipes each with a maximum of 24 optical fibres

FEATURES

- The splice box is suitable for cross-bonding and straight-through joints
- Gel-sealing technology ensures reliable operation even when buried joints are used
- Enhanced fibre management
- The splice box is easy to open and close without the use of special tools
- The kits are available for all Raychem joints





Chapter IV High voltage connectors

High Voltage Connectors for Outdoor Terminations	58
--	----



High Voltage Connectors for Outdoor Terminations

APPLICATION

- Our full line of connectors and accessories for high voltage cable accessories covers most applications in an electrical network. These connectors are typically used for the connection of outdoor terminations to bus bars or overhead lines. Industry leading Raychem high voltage cable accessories are combined with in-house engineered high-voltage connectors to make assemblies that are easy to install and completely reliable in the energy environment.

FEATURES

- High-strength aluminium alloy
- Various sizes available
- Individual solutions and special designs are available upon request
- High reliability and operates under extreme environmental conditions
- Fast and safe installation
- Excellent electrical and mechanical performance
- Easy installation with socket wrench

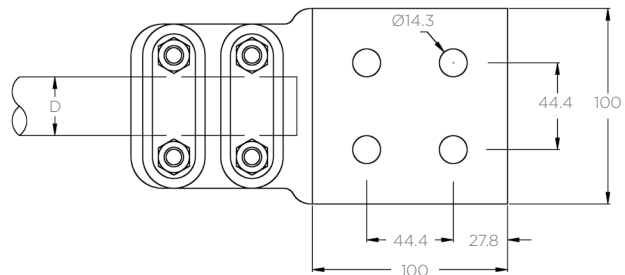
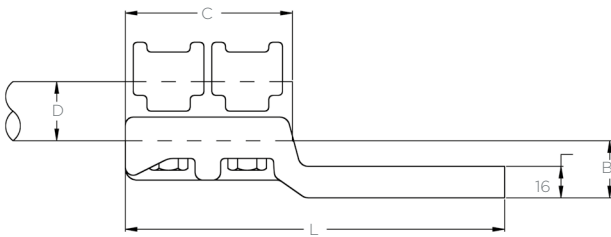

Terminal Pad (NEMA)

Description	D	B	C	L	RPN
CD 82 30 100 C290	26 - 31	29	85	193	707021-1
CD 82 40 100 C290	36 - 41	32	92	200	707127-1
CD 82 50 100 C290	46 - 51	25	94	207	718671-1

NOTE Dimensions in mm

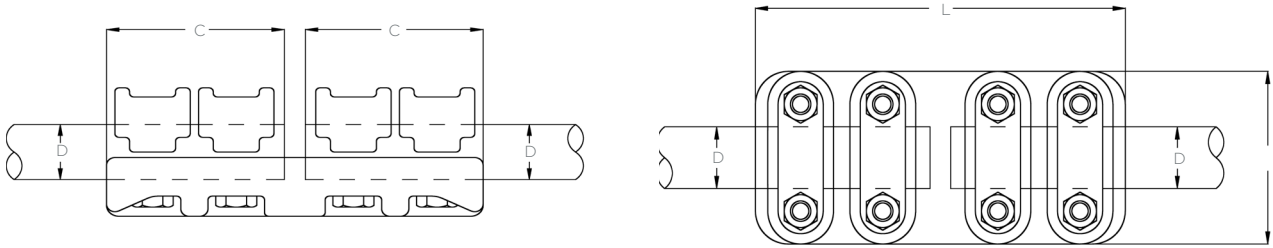

Straight Rod

Description	D	C	L	RPN
RD 82 30	26 - 31	85	180	706684-1
RD 82 40	36 - 41	92	195	706685-1
RD 82 50	46 - 51	94	200	1510395-1
4TG82T60	56 - 61	92	200	707216-1

NOTE Dimensions in mm

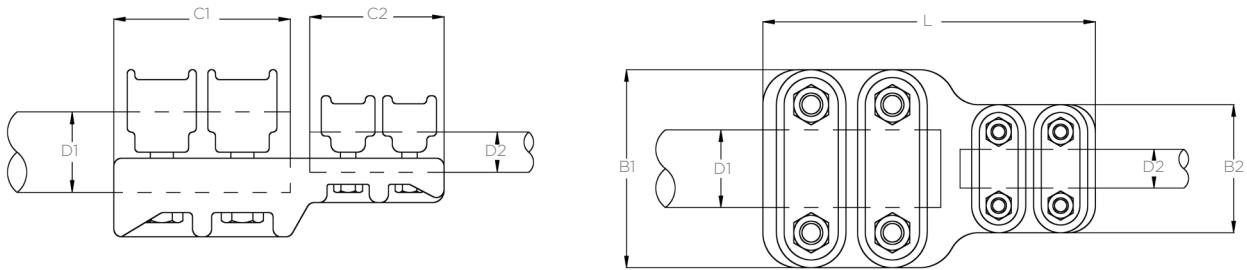

Straight Transition Rod

Description	D1	D2	B1	B2	C1	C2	L	RPN
RD 82 30 20	26 - 31	16 - 21	84	66	85	70	165	706948-1
RD 82 30 25	26 - 31	21 - 26	84	66	85	70	165	706636-1
RD 82 35 30	26 - 31	31 - 36	84	84	85	85	180	706949-1
RD 82 40 20	26 - 31	16 - 21	102	66	92	70	172	706700-1
RD 82 40 25	36 - 41	21 - 26	102	66	92	70	172	706635-1
RD 82 40 30	36 - 41	26 - 31	102	84	92	85	187	706655-1
RD 82 40 35	36 - 41	31 - 36	102	84	92	85	187	706663-1
RD 82 35 30	36 - 41	16 - 21	112	66	92	70	174	712016-1
RD 82 35 30	46 - 51	21 - 26	112	66	92	70	174	716341-1
RD 82 35 30	46 - 51	26 - 31	112	84	92	85	189	711000-1
RD 82 35 30	46 - 51	31 - 36	112	84	92	85	189	711002-1
RD 82 35 30	46 - 51	36 - 41	112	102	92	92	196	711001-1

NOTE Dimensions in mm

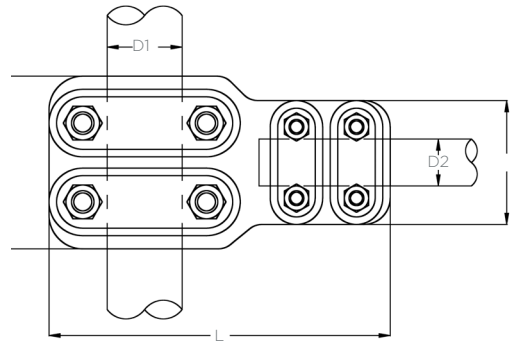
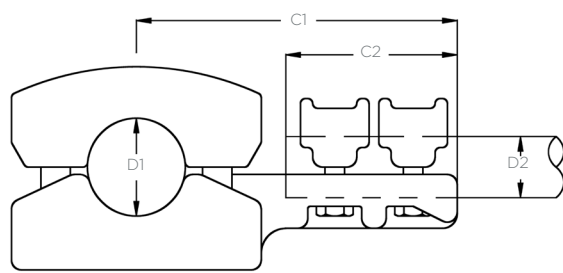

T - Rod

Description	D1	D2	B1	B2	C1	C2	L	RPN
T 82 30 20	26 - 31	16 - 21	124	70	166	716192-1	165	706948-1
T 82 30 25	26 - 31	21 - 26	124	70	166	706686-1	165	706636-1
T 82 30	26 - 31	26 - 31	140	85	182	706627-1	180	706949-1
T 82 30 35	26 - 31	31 - 36	140	85	182	706683-1	172	706700-1
T 82 30 40	26 - 31	36 - 41	143	92	195	706667-1	172	706635-1
T 82 40 20	36 - 41	16 - 21	131	70	182	716198-1	187	706655-1
T 82 40 25	36 - 41	21 - 26	131	70	182	716106-1	187	706663-1
T 82 40 30	36 - 41	26 - 31	146	85	197	706624-1	174	712016-1
T 82 40 35	36 - 41	31 - 36	146	85	207	706623-1	174	716341-1
T 82 40	36 - 41	36 - 41	151	92	207	711001-1	189	711000-1
T 82 50 20	46 - 51	16 - 21	135	70	191	716203-1	189	711002-1
T 82 50 25	46 - 51	21 - 26	135	70	191	718670-1	196	711001-1
T 82 50 30	46 - 51	26 - 31	151	85	207	716342-1	180	706949-1
T 82 50 35	46 - 51	31 - 36	151	85	207	716204-1	172	706700-1
T 82 50 40	46 - 51	36 - 41	158	92	214	706664-1	172	706635-1
T 82 60 20	56 - 61	16 - 21	143	70	176	706778-1	187	706655-1
T 82 60 25	56 - 61	21 - 26	143	70	176	716206-1	187	706663-1
T 82 60 30	56 - 61	26 - 31	153	85	190	706633-1	174	712016-1
T 82 60 35	56 - 61	31 - 36	153	85	190	716207-1	174	716341-1
T 82 60 40	56 - 61	36 - 41	160	92	196	716208-1	189	711000-1
T 82 60 45	56 - 61	41 - 46	160	92	196	716209-1	189	711002-1

NOTE Dimensions in mm

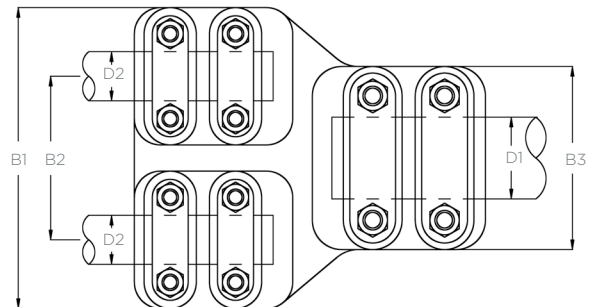
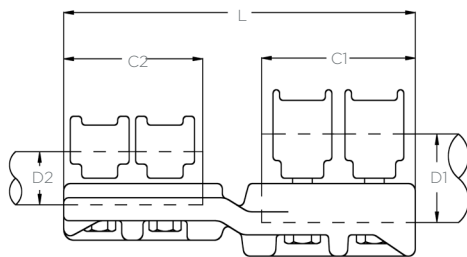

Twin Straight Rod

Description	D1	D2	B1	B2	B3	C1	C2	L	RPN
RD 82 F 30 E100 50	46 - 51	36 - 41	184	100	112	94	85	214	789025-1
RD 82 F 35 E100 50	46 - 51	31 - 36	184	100	122	94	85	214	717157-1
RD 82 F 40 E105 50	46 - 51	36 - 41	207	105	112	94	85	230	714766-2

NOTE Dimensions in mm

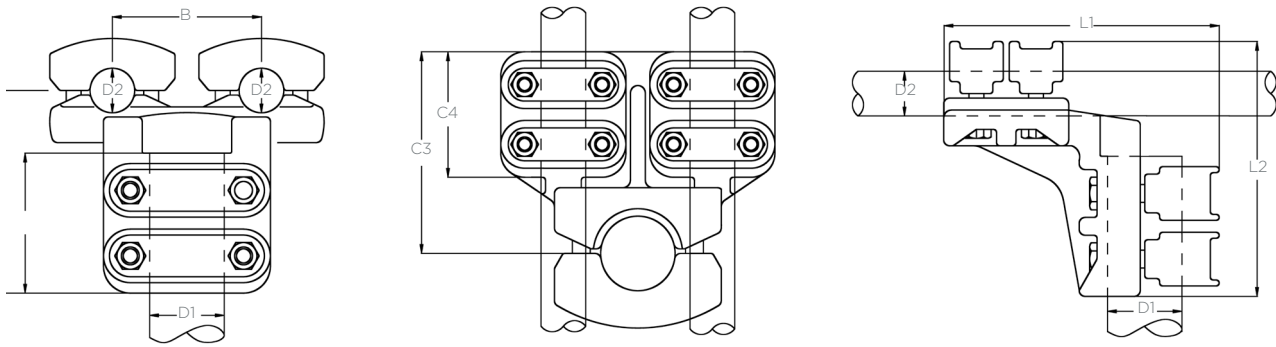

Twin T-Rod

Description	D1	D2	B	C3	C4	L1	L2	RPN
T 82 F 30 E100 50	46 - 51	26 - 31	100	134	84	135	136	793423-1
T 82 F 35 E100 50	46 - 51	31 - 36	100	134	84	135	136	0793337-1
T 82 F 40 E100 50	46 - 51	36 - 41	105	145	92	145	145	1306071-1
T 82 F 30 E100 60	56 - 61	26 - 31	100	131	94	140	131	1830731-1
T 82 F 35 E100 60	56 - 61	31 - 36	100	131	94	140	131	792694-1
T 82 F 40 E105 60	56 - 61	36 - 41	105	145	92	140	131	718666-1

NOTE Dimensions in mm

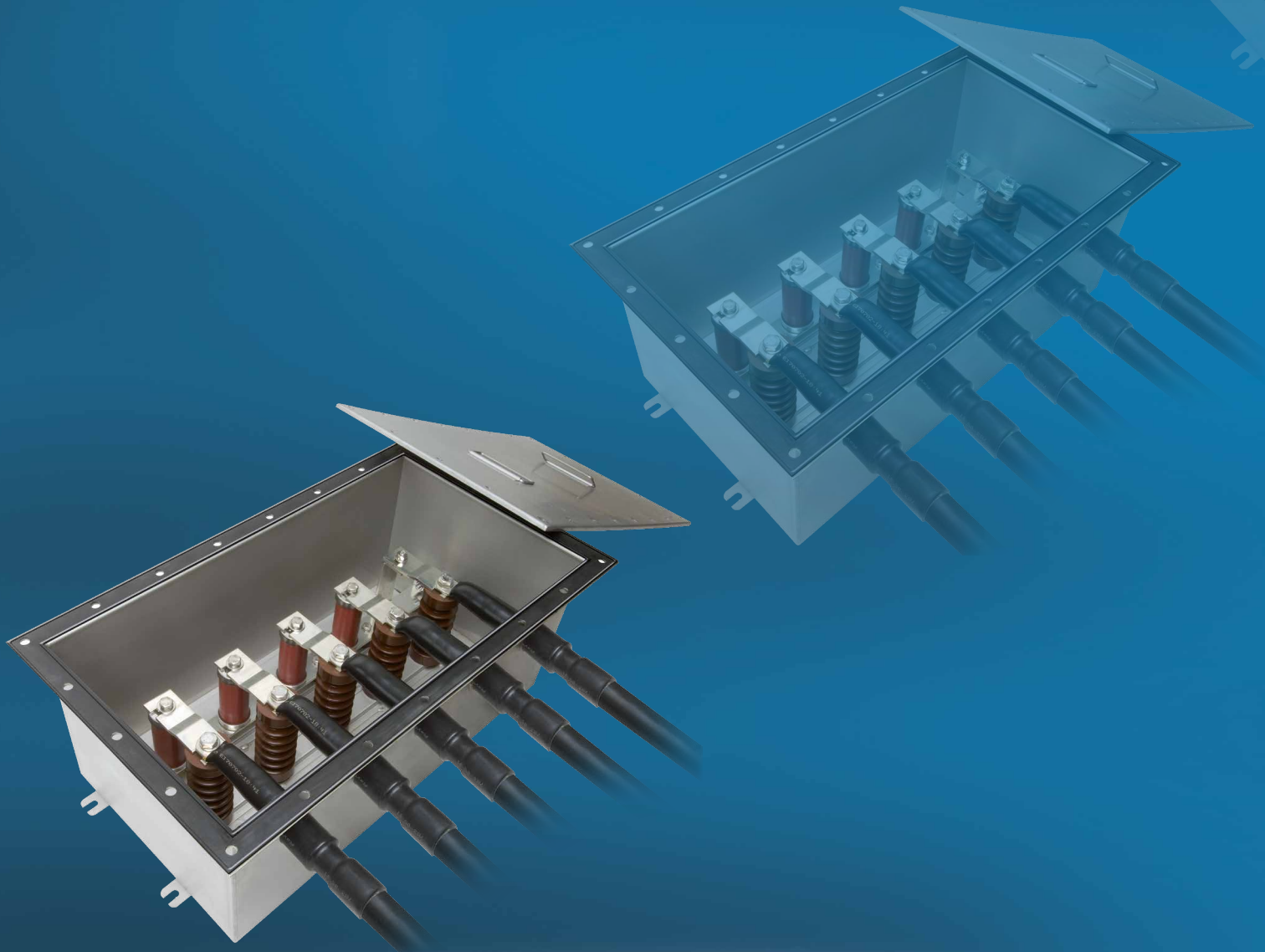



Chapter V Link boxes

Link Boxes.....	64
Link Boxes Selection Tables.....	66



Link Boxes

APPLICATION

- Single-core cables in operation carry alternating currents and induced voltages in the metallic sheath of the cable. Depending on the sheath bonding, these currents may lead to circulating currents flowing in the cable sheath, which reduces the transmission capacity of the cable and causes additional heating
- Link boxes are used for earthing and bonding cable sheaths of single-core cables so that the induced voltages and circulating currents are eliminated or reduced

FEATURES

- Various designs available
- Stainless steel box
- Various mechanical protection levels up to IP68
- Electrically and mechanically type tested
- 1-phase and 3-phase boxes
- With or without surge arresters
- With or without removable links
- For concentric cables or single-core cables
- Cross sections up to 300 mm²
- ZnO sheath voltage limiter for up to 7 kV protection levels, larger protection levels upon request
- Short circuit current up to 40 kA 1 sec

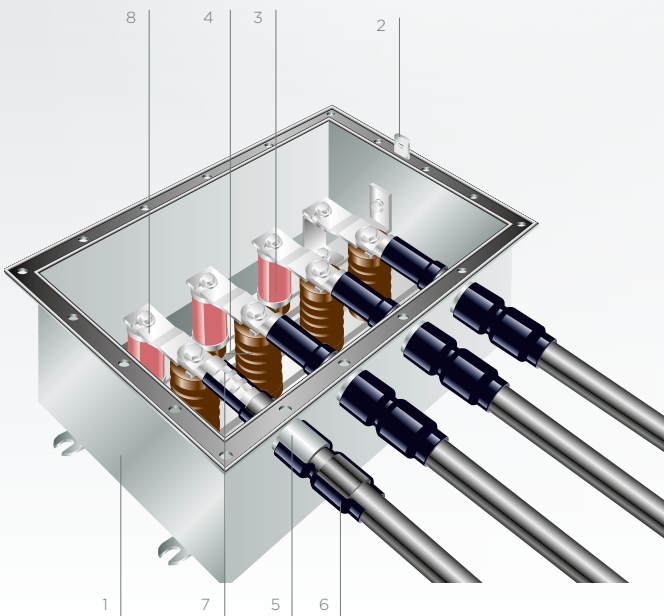

- 1 Stainless steel housing
- 2 Lockable lid
- 3 Sheath voltage limiters (optional)
- 4 Epoxy resin post-insulators
- 5 Cable entries
- 6 Outer sealing
- 7 Compression lugs
- 8 Tinned copper links

Most Popular Cable Sheath Grounding Options

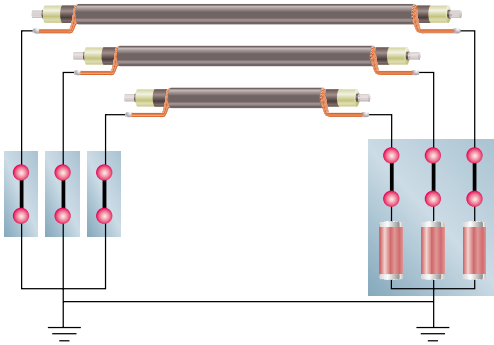

Single point earthing

On relatively short cable sections, the cable sheaths are solidly bonded together and earthed at one position. The sheaths of the three cable sections are connected and grounded at one point only. At all other points, there is a voltage between sheath and ground that is at its maximum at the farthest point from the ground bond. Since there is no closed sheath circuit, current does not flow along the sheaths and no sheath circulation current loss occurs.

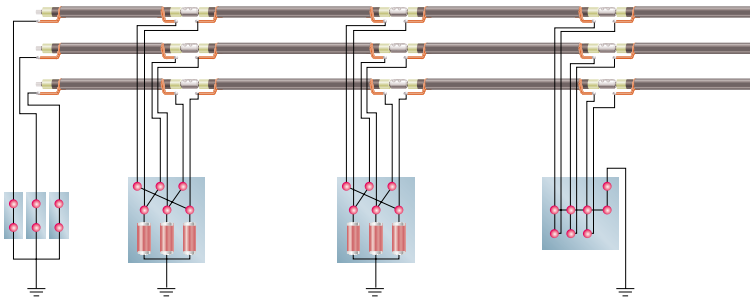

Cross bonding

The cable route is sectionalized into equal lengths. The sections are cross-connected to neutralize the induced voltages. The phase sum of the introduced voltages is zero and, therefore, there is no circulating currents when the cable laying is symmetrical.

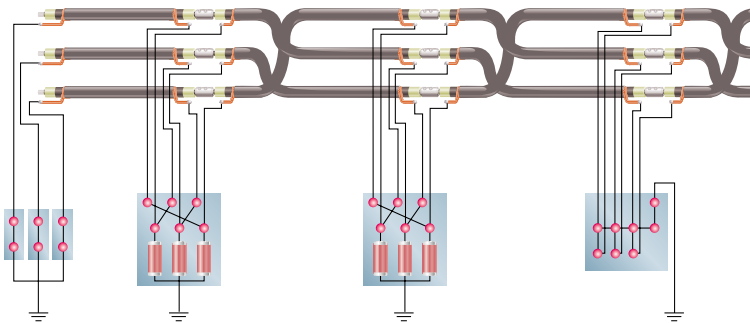

Cross bonding and transposition

For cable laying in unsymmetrical formations, the induced voltages are not equal at each phase and, therefore, the phase sum of the voltages is not zero despite cross-bonding. The cables are transposed at each joint position and the cable sheaths are cross-connected, with each cable occupying the same relative position in the cable formation. By this means, the phase sum of the induced voltage sheaths is the same over three sections.

Typical application example

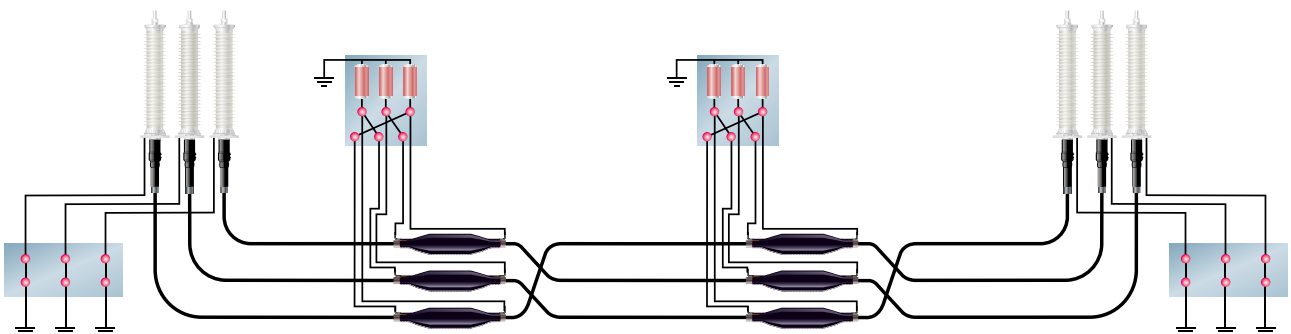

Selection Tables for Raychem Link Boxes for Single Core Cables

Link Diagram

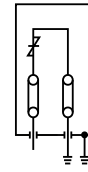
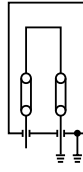

Bonding lead (type)	Single-core	Single-core
Bonding lead (mm ²)	70 - 300	70 - 300
Protection class	IP 68	IP 68
Application	Buried	Buried
Sheath voltage limiters	N/A	1 kV-6 kV
Box size (LxHxW) (mm)	496x322x451	496x322x451
Material	Stainless steel	Stainless steel
Total weight	Approx. 35 kg	Approx. 35 kg
Connection links	Removable tinned copper 300 mm ²	Removable tinned copper 300 mm ²
Cable connection	Compression lug	Compression lug
Impulse withstand voltage (kV)	55	55
AC withstand voltage (kV)	25	25
DC withstand voltage (kV)	25	25
Short circuit current (kA/1s)	40	40
Description	HVLB-E-S-0-1-2-U-IP68	HVLB-E-S-x*-1-2-U-IP68

* Indicates voltage class of sheath voltage limiter (SVL)

Link Diagram

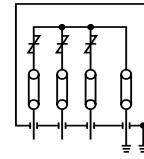
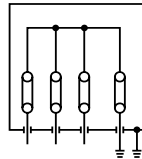

Bonding lead (type)	Single-core	Single-core
Bonding lead (mm ²)	70 - 300	70 - 300
Protection class	IP 68	IP 68
Application	Buried	Buried
Sheath voltage limiters	N/A	1 kV-6 kV
Box size (LxHxW) (mm)	496x322x725	496x322x725
Material	Stainless steel	Stainless steel
Total weight	Approx. 65 kg	Approx. 65 kg
Connection links	Removable tinned copper 300 mm ²	Removable tinned copper 300 mm ²
Cable connection	Compression lug	Compression lug
Impulse withstand voltage (kV)	55	55
AC withstand voltage (kV)	25	25
DC withstand voltage (kV)	25	25
Short circuit current (kA/1s)	40	40
Description	HVLB-E-S-0-3-2-U-IP68	HVLB-E-S-x*-3-2-U-IP68

* Indicates voltage class of sheath voltage limiter (SVL)

Link Diagram

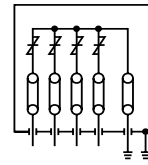
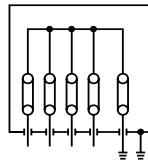

Bonding lead (type)	Single-core	Single-core
Bonding lead (mm ²)	70 - 300	70 - 300
Protection class	IP 68	IP 68
Application	Buried	Buried
Sheath voltage limiters	N/A	1 kV-6 kV
Box size (LxHxW) (mm)	496x322x862	496x322x862
Material	Stainless steel	Stainless steel
Total weight	Approx. 75 kg	Approx. 75 kg
Connection links	Removable tinned copper 300 mm ²	Removable tinned copper 300 mm ²
Cable connection	Compression lug	Compression lug
Impulse withstand voltage (kV)	55	55
AC withstand voltage (kV)	25	25
DC withstand voltage (kV)	25	25
Short circuit current (kA/1s)	40	40
Description	HVLB-E-S-0-3-2-U-IP68	HVLB-E-S-x*-3-2-U-IP68

* Indicates voltage class of sheath voltage limiter (SVL)

Link Diagram

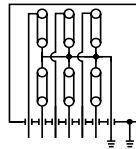

Bonding lead (type)	Single-core
Bonding lead (mm ²)	70 - 300
Protection class	IP 68
Application	Buried
Sheath voltage limiters	N/A
Box size (LxHxW) (mm)	496x322x995
Material	Stainless steel
Total weight	Approx. 85 kg
Connection links	Removable tinned copper 300 mm ²
Cable connection	Compression lug
Impulse withstand voltage (kV)	55
AC withstand voltage (kV)	25
DC withstand voltage (kV)	25
Short circuit current (kA/1s)	40
Description	HVLB-E-S-0-6-2-U-IP68

Link Diagram

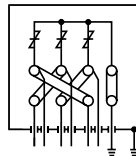

Bonding lead (type)	Single-core
Bonding lead (mm ²)	70 - 300
Protection class	IP 68
Application	Buried
Sheath voltage limiters	1 kV-6 kV
Box size (LxHxW) (mm)	665x395x665
Material	Stainless steel
Total weight	Approx. 65 kg
Connection links	Removable tinned copper 300 mm ²
Cable connection	Clamping ring
Impulse withstand voltage (kV)	55
AC withstand voltage (kV)	25
DC withstand voltage (kV)	25
Short circuit current (kA/1s)	40
Description	HVLB-C-S-x*-6-2-U-IP68

* Indicates voltage class of sheath voltage limiter (SVL)

Link Boxes

Link Diagram

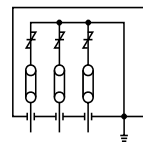
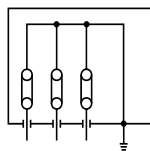

Bonding lead (type)	Single-core	Single-core
Bonding lead (mm ²)	95 - 300	95 - 300
Protection class	IP 56	IP 56
Application	Non buried	Non buried
Sheath voltage limiters	N/A	1 kV-6 kV
Box size (LxHxW) (mm)	310x255x310	310x255x310
Material	Stainless steel	Stainless steel
Total weight	Approx. 16 kg	Approx. 16 k
Connection links	Removable copper 240 mm ²	Removable copper 240 mm ²
Cable connection	Compression lug	Compression lug
Impulse withstand voltage (kV)	35	35
AC withstand voltage (kV)	24	24
DC withstand voltage (kV)	40	40
Short circuit current (kA/1s)	-	-
Description	HVLB-GND-0-3	HVLB-GND-x*-3

* Indicates voltage class of sheath voltage limiter (SVL)

Link Diagram

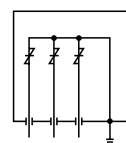
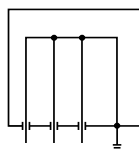

Bonding lead (type)	Single-core	Single-core
Bonding lead (mm ²)	95 - 300	95 - 300
Protection class	IP 56 or IP 68	IP 56 or IP 68
Application	Non buried	Non buried
Sheath voltage limiters	N/A	1 kV-6 kV
Box size (LxHxW) (mm)	310x255x310	310x255x310
Material	Stainless steel	Stainless steel
Total weight	Approx. 16 kg	Approx. 16 k
Connection links	Copper 120 mm ²	Copper 120 mm ²
Cable connection	Compression lug	Compression lug
Impulse withstand voltage (kV)	35	35
AC withstand voltage (kV)	24	24
DC withstand voltage (kV)	40	40
Short circuit current (kA/1s)	-	-
Description	EPPA-055-0-3	EPPA-055-x*-3

* Indicates voltage class of sheath voltage limiter (SVL)

Link Diagram

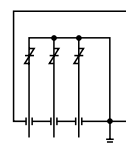
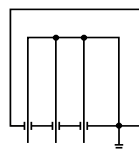

Bonding lead (type)	Single-core	Single-core
Bonding lead (mm ²)	95 - 300	95 - 300
Protection class	IP 56 or IP 68	IP 56 or IP 68
Application	Non buried	Non buried
Sheath voltage limiters	N/A	1 kV-6 kV
Box size (LxHxW) (mm)	310x255x310	310x255x310
Material	Stainless steel	Stainless steel
Total weight	Approx. 16 kg	Approx. 16 k
Connection links	Copper 120 mm ²	Copper 120 mm ²
Cable connection	Compression lug	Compression lug
Impulse withstand voltage (kV)	35	35
AC withstand voltage (kV)	24	24
DC withstand voltage (kV)	40	40
Short circuit current (kA/1s)	-	-
Description	EPPA-055-0-3	EPPA-055-x*-3

* Indicates voltage class of sheath voltage limiter (SVL)

Link Diagram

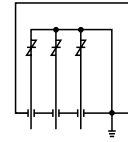
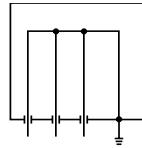

Bonding lead (type)	Single-core	Single-core
Bonding lead (mm ²)	95 - 300	95 - 300
Protection class	IP 56 or IP 68	IP 56 or IP 68
Application	Non buried	Non buried
Sheath voltage limiters	N/A	1 kV-6 kV
Box size (LxHxW) (mm)	310x255x310	310x255x310
Material	Stainless steel	Stainless steel
Total weight	Approx. 16 kg	Approx. 16 k
Connection links	Copper 120 mm ²	Copper 120 mm ²
Cable connection	Compression lug	Compression lug
Impulse withstand voltage (kV)	35	35
AC withstand voltage (kV)	24	24
DC withstand voltage (kV)	40	40
Short circuit current (kA/1s)	-	-
Description	EPPA-055-0-3	EPPA-055-x*-3

* Indicates voltage class of sheath voltage limiter (SVL)

Link Diagram

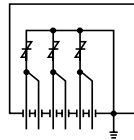

Bonding lead (type)	Single-core
Bonding lead (mm ²)	95 - 300
Protection class	IP 56 or IP 68
Application	Non buried
Sheath voltage limiters	1 kV-6 kV
Box size (LxHxW) (mm)	310x255x310
Material	Stainless steel
Total weight	Approx. 16 kg
Connection links	Copper 120 mm ²
Cable connection	Compression lug
Impulse withstand voltage (kV)	35
AC withstand voltage (kV)	24
DC withstand voltage (kV)	40
Short circuit current (kA/1s)	-
Description	EPPA-055-x*-3

* Indicates voltage class of sheath voltage limiter (SVL)

Link Diagram

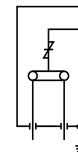
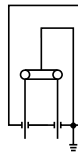

Bonding lead (type)	Single-core	Single-core
Bonding lead (mm ²)	95 - 300	95 - 300
Protection class	IP 56	IP 56
Application	Non buried	Non buried
Sheath voltage limiters	N/A	1 kV-6 kV
Box size (LxHxW) (mm)	300x165x190	300x165x190
Material	Stainless steel	Stainless steel
Total weight	Approx. 10 kg	Approx. 11 kg
Connection links	Removable copper 120 mm ²	Removable copper 120 mm ²
Cable connection	Compression lug	Compression lug
Impulse withstand voltage (kV)	35	35
AC withstand voltage (kV)	24	24
DC withstand voltage (kV)	40	40
Short circuit current (kA/1s)	-	-
Description	EPPA-055-0-1	EPPA-055-x*-1

* Indicates voltage class of sheath voltage limiter (SVL)

Link Diagram

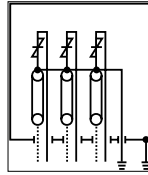

Bonding lead (type)	Concentric (coaxial)
Bonding lead (mm ²)	70 - 300
Protection class	IP 68
Application	Buried
Sheath voltage limiters	1 kV-6 kV
Box size (LxHxW) (mm)	665x395x665
Material	Stainless steel
Total weight	Approx. 68 kg
Connection links	Removable tinned copper 300 mm ²
Cable connection	Clamping ring
Impulse withstand voltage (kV)	55
AC withstand voltage (kV)	25
DC withstand voltage (kV)	25
Short circuit current (kA/1s)	40
Description	HVLB-E-C-x*-3-2-U-IP68

* Indicates voltage class of sheath voltage limiter (SVL)

Link Diagram

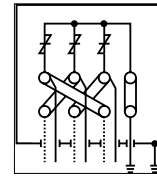
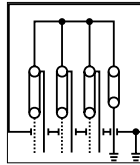

Bonding lead (type)	Concentric (coaxial)	Concentric (coaxial)
Bonding lead (mm ²)	70 - 300	70 - 300
Protection class	IP 68	IP 68
Application	Buried	Buried
Sheath voltage limiters	N/A	1 kV-10 kV
Box size (LxHxW) (mm)	621x356x883	621x356x883
Material	Stainless steel	Stainless steel
Total weight	Approx. 100 kg	Approx. 100 kg
Connection links	Removable tinned copper 300 mm ²	Removable tinned copper 300 mm ²
Cable connection	Clamping ring	Clamping ring
Impulse withstand voltage (kV)	55	55
AC withstand voltage (kV)	25	25
DC withstand voltage (kV)	25	25
Short circuit current (kA/1s)	25	25
Description	HVLB-E-C-0-3-2-68	HVLB-C-C-x*-3-2-68

* Indicates voltage class of sheath voltage limiter (SVL)

TE Connectivity (NYSE: TEL) is a \$14 billion global technology leader. Our connectivity and sensor solutions are essential in today's increasingly connected world. We collaborate with engineers to transform their concepts into creations – redefining what's possible using intelligent, efficient and high-performing TE products and solutions proven in harsh environments. Our 80,000 people, including 7,500 design engineers, partner with customers in over 150 countries across a wide range of industries. We believe EVERY CONNECTION COUNTS – www.TE.com.

- Mining
- Nuclear power plants
- OEMs
- Overhead distribution
- Petrochemical plants
- Railways
- Street lighting
- Substations
- Transmission lines
- Underground distribution
- Windfarms
- Solar
- Hydro-electric

WHEREVER ELECTRICITY FLOWS, YOU'LL FIND TE ENERGY



te.com/energy

FOR MORE INFORMATION:

TE Technical Support Centers

France:	+ 33 380 583 200	Italy:	+ 39 333 2500 915
Germany:	+ 49 896 089 903	Poland and Baltics:	+ 48 224 576 753
UK:	+ 44 8 708 707 500	Czech Republic:	+ 42 0 272 011 105
Spain:	+ 34 916 630 400	Sweden and Norway:	+ 46 850 725 000
Benelux:	+ 32 16 351 731	Middle East:	+ 971 4 2 117 000
Denmark:	+ 45 43 480 424	USA:	+ 1 800 327 6996

te.com/energy

©2015 TE Connectivity Ltd. family of companies. All Rights Reserved. EPP-1946-9/15

Raychem, TE Connectivity and the TE connectivity (logo) are trademarks of the TE Connectivity Ltd. family of companies. Other logos, product and Company names mentioned herein may be trademarks of their respective owners. While TE has made every reasonable effort to ensure the accuracy of the information in this brochure, TE does not guarantee that it is error-free, nor does TE make any other representation, warranty or guarantee that the information is accurate, correct, reliable or current. TE reserves the right to make any adjustments to the information contained herein at any time without notice. TE expressly disclaims all implied warranties regarding the information contained herein, including, but not limited to, any implied warranties of merchantability or fitness for a particular purpose. The dimensions in this brochure are for reference purposes only and are subject to change without notice. Specifications are subject to change without notice. Consult TE for the latest dimensions and design specifications.